

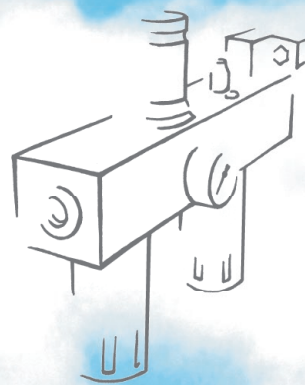

METAL[®]
WORK
P N E U M A T I C













SYNTESI[®]



SYNTESI[®]

UNITS

SUMMARY Syntesi®

	● INTRODUCTION	PAGE 4
	● KEY TO CODES	PAGE 7
	● FILTER	PAGE 8
	● DEPURATOR	PAGE 11
	● ACTIVE CARBON FILTER	PAGE 14
	● REGULATOR	PAGE 17
	● IN-SERIES REGULATOR	PAGE 20
	● FILTER-REGULATOR	PAGE 23
	● LUBRICATOR	PAGE 27
	● SHUT-OFF VALVE	PAGE 30
	● PROGRESSIVE STARTER	PAGE 33
	● PRESSURE SWITCHES	PAGE 35
	● AIR TAKE-OFF	PAGE 37



● **FR+LUB**

PAGE 38



● **V3V+FR+LUB**

PAGE 40



● **FIL+DEP**

PAGE 42



● **FIL+LUB**

PAGE 44

● **ACCESSORIES**

PAGE 46

● **SPARE PARTS**

PAGE 47

AIR TREATMENT UNIT SYNTESI®

Syntesi® is an important milestone achieved by Metal Work, the result of thirty years' experience producing air-treatment units. It has been studied in minute detail to obtain the best possible performance in a reduced space and with limited weight. The capacity is much higher than that of other units of the same size.

This modular unit features a very simple yet effective system that requires no brackets, stay bolts or yoke for assembling the elements.

The basic version of Syntesi® incorporates numerous functions that are not provided or are only optional with traditional units. Examples are padlockable knobs, additional pneumatic ports on the front and back, flow options from left to right or vice versa, regulators with compensation system - which are accurate even when the upstream pressure changes, with rapid downstream pressure relief - full indelible marking, automatic condensate drain even in size 1, and 360° visual inspection of oil and condensate levels. The basic materials, technopolymer and nickel-plated brass have excellent corrosion resistance. An anti-corrosion version is available with stainless steel components (screws, plates) or Geomet®-treated ones (regulator springs).

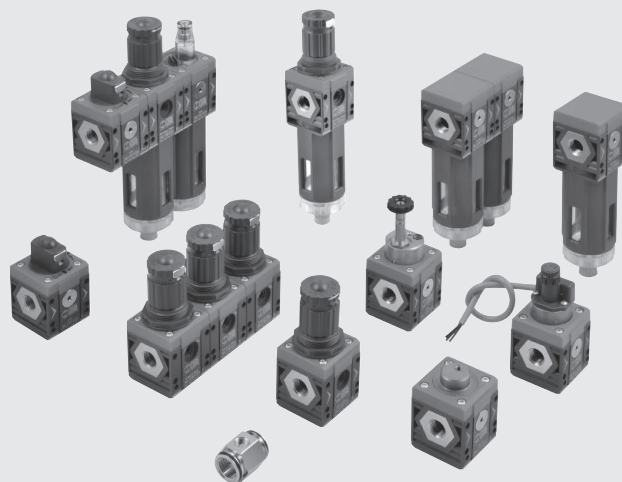

TECHNICAL DATA	SIZE 1			SIZE 2			
	1/8"	1/4"	3/8"	3/8"	1/2"	3/4"	1"
Threaded port	1/8"	1/4"	3/8"	3/8"	1/2"	3/4"	1"
Max. input pressure	bar			13			
	MPa			1.3			
	psi			188			
Flow rate				See catalogue of the various elements			
Min/max temperature at 10 bar; 1 MPa; 145 psi	°C			from -10 to +50			
Padlockable knob	The knobs of the regulators, filter regulators and standard sectioning valves can all be padlocked						
Fluid	Compressed air or other inert gases						
Mounting position	See catalogue of the various elements						
Direction of flow	Flow options right to left or vice versa						
Additional air take-off, for pressure gauges or fittings	1/8", front and rear, on all modules			1/4", front and rear, on all modules			
Wall fixing screws	No. 2 M4 screws			No. 2 M5 screws			
Certification for potentially explosive atmosphere according to 94/9/CE	Ex II 3 GD c T5 T 100°C -20°C<Ta<50°C						

ANTI-CORROSION VERSION

Differences compared to the standard version:

- stainless steel screws
- stainless steel plate for R, FR, V3V knobs
- Geomet®-treated regulator spring and filter-regulator

MODULARITY AND FLEXIBILITY

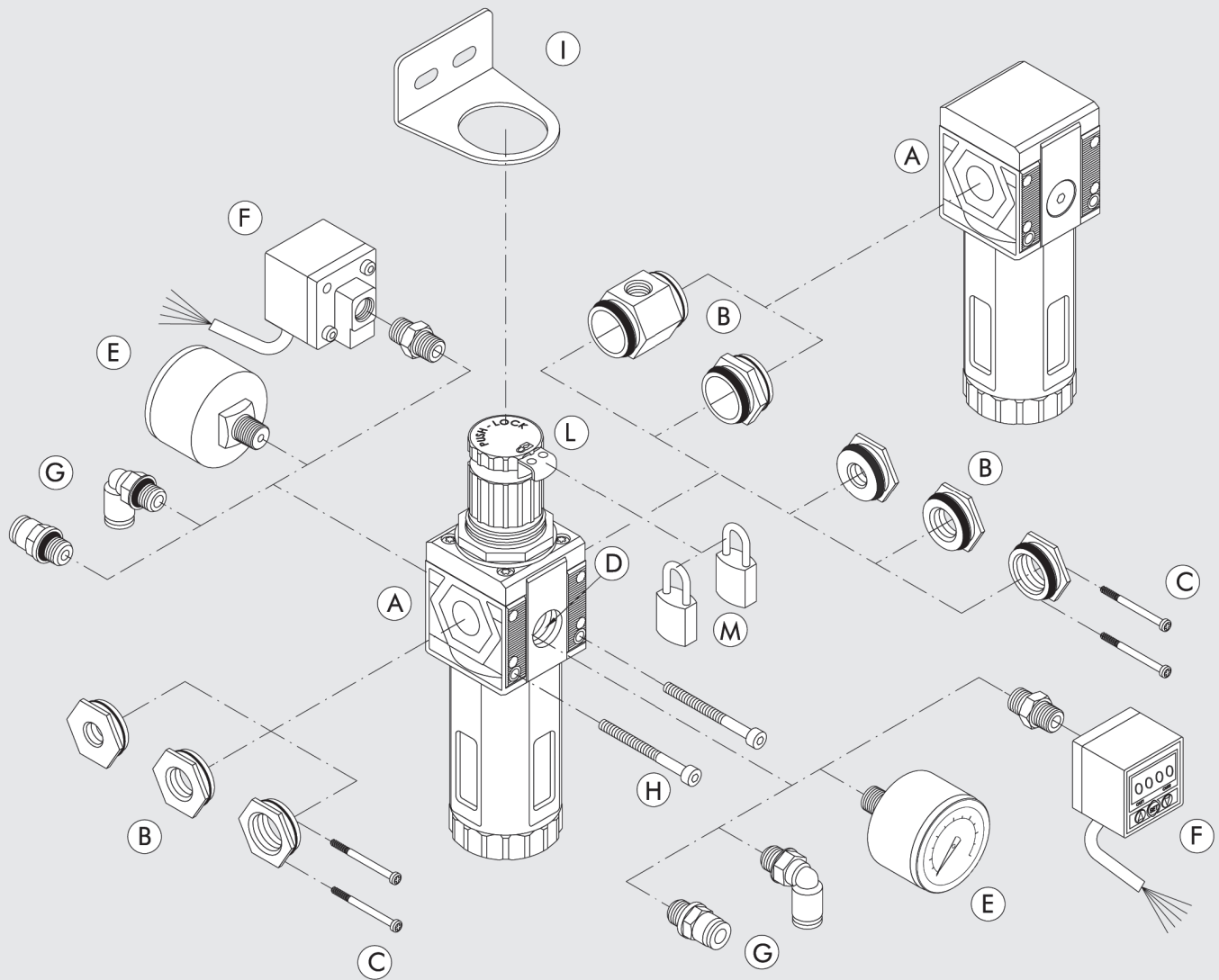

The various elements **A** of Syntesi® can be fixed together and connected to the air feed and delivery circuit using nickel brass or passivated aluminium bushes **B**.

The bushes are easy to remove by unscrewing the two front screws **C**. This solution has numerous advantages:

- Reduced overall dimensions.
- Free composition of multiple elements, without the need for brackets, stay bolts or yoke.
- The metal threads of the fittings, including taper thread, allow high torques.
- Maximum flexibility, a unit can be transformed at any time by adding an element or replacing a port with another one, e.g. 1/4" instead of 1/8".
- The pneumatic inlet port can be the same or different from the outlet port.

Standard ports Syntesi® are: 1/8", 1/4", 3/8" for size 1; 3/8", 1/2", 3/4", 1" for size 2; also an intermediate connection and an air intake are available.

For the insertion of the bushings on the size 2 it could be necessary to push with the assistance of a vice.

Additional ports **D.** On the front and back of all Syntesi® is an (1/8" for size 1, 1/4" for size 2) port for use with pressure gauges **E** or pressure switches **F** or, considering the high flow rate, as additional air take-off **C**. These ports are downstream of the element, so, for example, a regulator port can supply air at a set pressure or a filter port can supply filtered air (not valid for activated carbon filter and deparator).

Wall fixing. Only two through screws **H** are needed. No bulky brackets or additional flanges are required.

Regulator fixing bracket. The regulators and filter regulators can be fixed in position using a steel bracket **I**.

Padlockable knob **L.** The knobs on the regulators, filter regulator and sectioning valves can all be padlocked. The steel plate is included in the supply. You can insert up to two **M** padlocks on size 1, and up to three padlocks on size 2.

MOUNTING OPTIONS

On the wall, using two screws

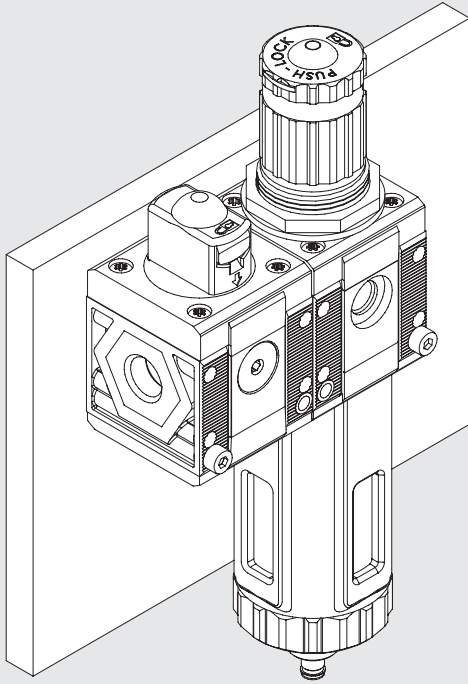

Using a bracket

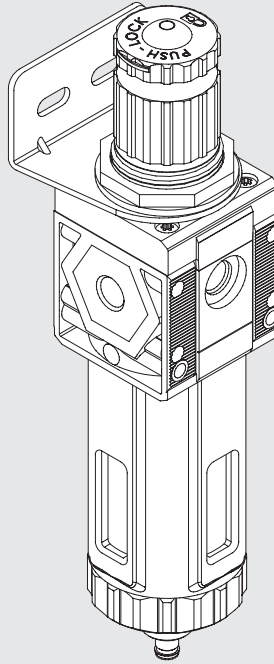

On a panel

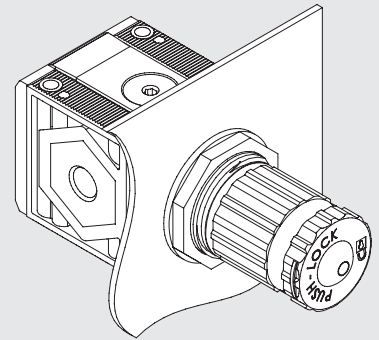

FIXING TO FRONT PORTS

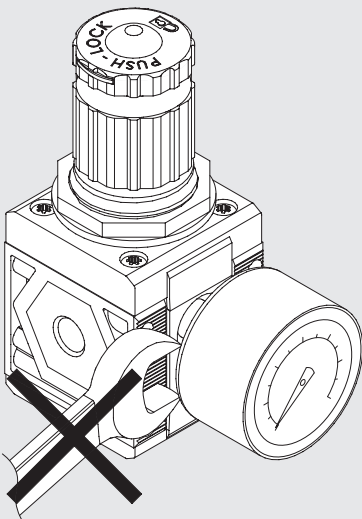

Do not use a spanner for fixing taper threaded elements to the front ports. Mount by hand and apply a liquid sealant (not teflon®).

ROTARY BUSHINGS

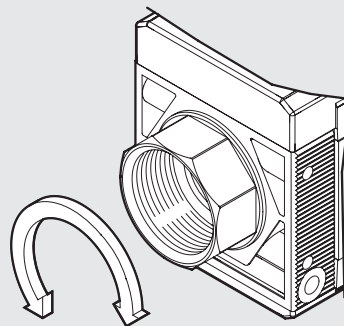

3/4" and 1" bushings in Size 2 rotate freely to facilitate assembly operations.

LASER MARKING

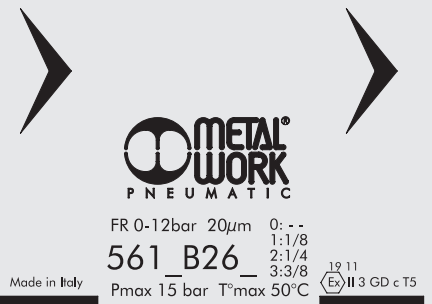

The following is marked indelibly on the body:

- Metal Work trademark
- Code
- Maximum pressure and temperature
- Degree of filtration or pressure range, where relevant
- Week and year of manufacture
- Atex category
- Made in Italy

KEY TO CODES SINGLE ELEMENT

56	1	1	F	10	1
SYNTESI	SIZE	THREADED INPUT CONNECTION	ELEMENT	TYPE	THREADED OUTPUT CONNECTION
56 Syntesi 5X Syntesi anti-corrosion	1 Size 1	0 Without bushing 1 1/8" port 2 1/4" port 3 3/8" port	F Filter D Depurator C Active carbon filter R Pressure regulator B Filter-regulator L Lubricator ● V Shut off valve ▲ A Progressive starter ▲ S Pressure switches P Air take-off	Varies from element to element	0 Without bushing 1 1/8" port 2 1/4" port 3 3/8" port
	2 Size 2	0 Without bushing 3 3/8" port 4 1/2" port 5 3/4" port 6 1" port			0 Without bushing 3 3/8" port 4 1/2" port 5 3/4" port 6 1" port

- The anti-corrosion version of this element is only available with manual actuation.
- ▲ Not available in the anti-corrosion version.

KEY TO CODES UNIT COMPOSED OF TWO OR THREE ELEMENTS

56	1	1	V	10	B	24	L	10	1
SYNTESI	SIZE	THREADED INPUT CONNECTION	ELEMENT 1	TYPE	ELEMENT 2	TYPE	ELEMENT 3	TYPE	THREADED OUTPUT CONNECTION
56 Syntesi 5X Syntesi anti-corrosion	1 Size 1	1 1/8" port 2 1/4" port 3 3/8" port	F Filter D Depurator C Active carbon filter R Pressure regulator B Filter-regulator L Lubricator ● V Shut off valve ▲ A Progressive starter ▲ S Pressure switches P Air Take-off	Varies from element to element	F Filter D Depurator C Active carbon filter R Pressure regulator B Filter-regulator L Lubricator ● V Shut off valve ▲ A Progressive starter ▲ S Pressure switches P Air Take-off	Varies from element to element	F Filter D Depurator C Active carbon filter R Pressure regulator B Filter-regulator L Lubricator ● V Shut off valve ▲ A Progressive starter ▲ S Pressure switches P Air Take-off	Varies from element to element	1 1/8" port 2 1/4" port 3 3/8" port
	2 Size 2	3 3/8" port 4 1/2" port 5 3/4" port 6 1" port							

- The anti-corrosion version of this element is only available with manual actuation.
- ▲ Not available in the anti-corrosion version.

SYNTESI® FILTER

The job of the filter is to retain liquid or solid impurities present in the compressed air.

The incoming air is moved by the centrifuge unit, so that liquid particles, which are heavier, are projected against the walls of the container and force to adhere to it. As they accumulate, they create drops that deposit on the bottom by gravity.

The remaining solid particles are held back by the porous filtering element. The condensate is maintained in a quiet state to prevent the deposited impurities from re-entering the circulation. The condensate drains out through the drain cock provided.

The RMSA drain discharges when the pressure in the filter drops to zero. Alternatively the condensate can be drained by hand by pressing the button.

The RA drain discharges condensate from the container automatically whenever necessary, regardless of the pressure level. On the front and back there is a port (1/8" for size 1 and 1/4" for size 2) that can be used with pressure gauges, pressure switches or as an additional filtered air intake.



UNITS

Syntesi® FILTER

TECHNICAL DATA	FIL SY1			FIL SY2			
	1/8"	1/4"	3/8"	3/8"	1/2"	3/4"	1"
Threaded port	1/8"	1/4"	3/8"	3/8"	1/2"	3/4"	1"
Degree of filtration	5 (yellow) - output air purity class ISO8573-1: 3.7.4 20 (white) - output air purity class ISO8573-1: 4.7.4 50 (blue) - output air purity class ISO8573-1: 5.7.4						
Max. input pressure	bar			13			
	MPa			1.3			
Flow rate at 6.3 bar (0.63 MPa; 91 psi) ΔP 0.5 bar (0.05 MPa; 7 psi)	psi			188			
	Nl/min	900	1200	1300	3400	3800	3800
Flow rate at 6.3 bar (0.63 MPa; 91 psi) ΔP 1 bar (0.1 MPa; 14 psi)	scfm	32	42	46	120	135	135
	Nl/min	1300	1650	1750	4500	5200	5200
Min/max temperature at 10 bar; 1 MPa; 145 psi	scfm	46	58	62	159	184	184
	°C	From -10 to +50			From -10 to +50		
Weight	g	178	173	164	488	461	445
Condensate drain	RMSA: drain with manual condensate discharge and automatic discharge at zero pressure RA: automatic drain with condensate discharge, independent of pressure and flow rate Note: the maximum input pressure for the RA version must not exceed 10 bar Compressed air or other inert gases						
Fluid	Compressed air or other inert gases						
Condensate bowl capacity	cm³			70			
Mounting position	Vertical			Vertical			
Port for additional air take-off	1/8", front and rear			1/4", front and rear			
Additional air take-off flow rate at 6.3 bar (0.63 MPa; 91 psi) ΔP 1 bar (0.1 MPa; 14 psi)	Nl/min			1500			
	scfm	500			53		
Wall fixing screws	No. 2 M4 screws			No. 2 M5 screws			

COMPONENTS

- ① Technopolymer filter body
- ② IN/OUT bushing made of OT58 nickel-plated brass or passivated aluminium for 3/4" - 1"
- ③ Technopolymer centrifuge
- ④ Sintered HDPE filter cartridge
- ⑤ Technopolymer screen
- ⑥ Drain (RMSA)
- ⑦ Technopolymer plate
- ⑧ NBR o-ring gaskets
- ⑨ Clear technopolymer bowl

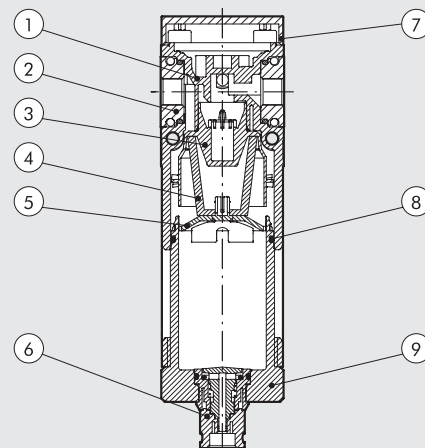

FLOW CHARTS

FIL Syntesi® SY1 1/8"

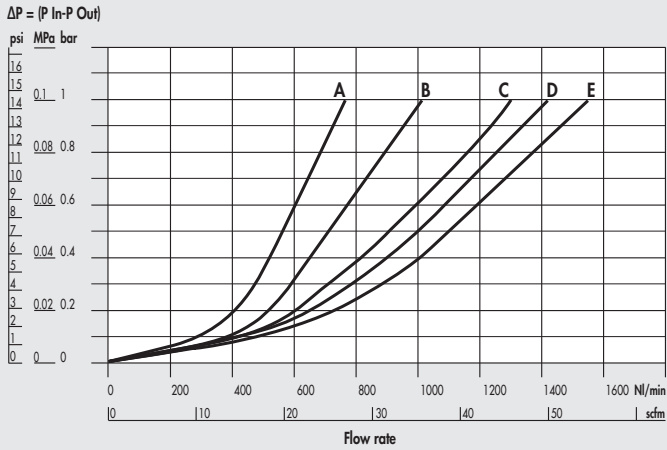

FIL Syntesi® SY1 1/4"

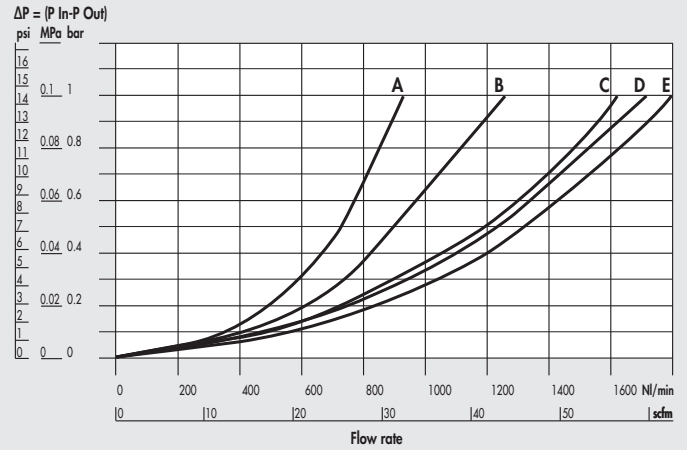

FIL Syntesi® SY1 3/8"

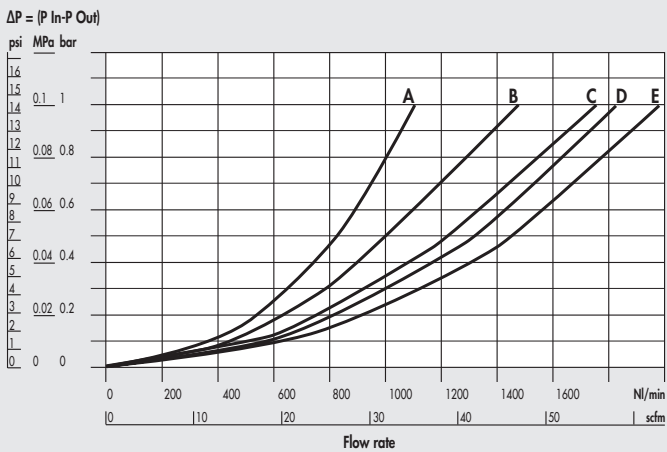

FIL Syntesi® SY2 3/8"

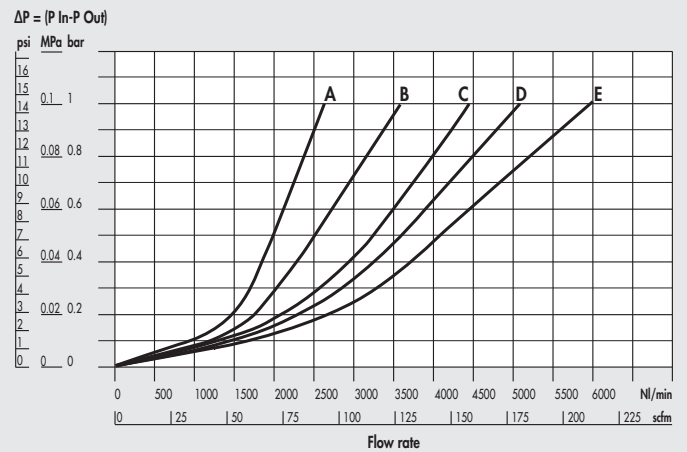

FIL Syntesi® SY2 1/2"

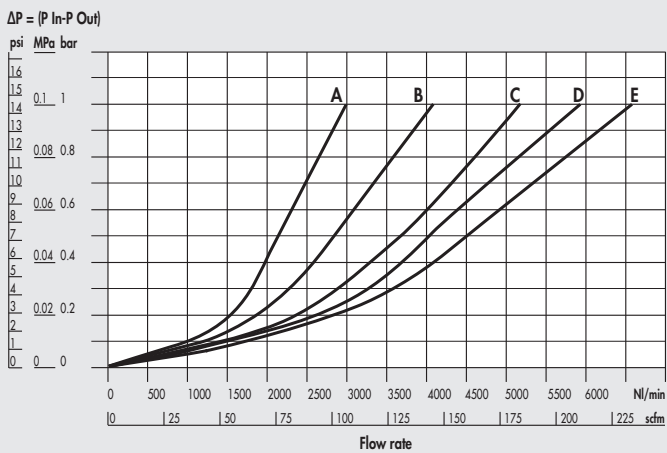

FIL Syntesi® SY2 3/4"-1"

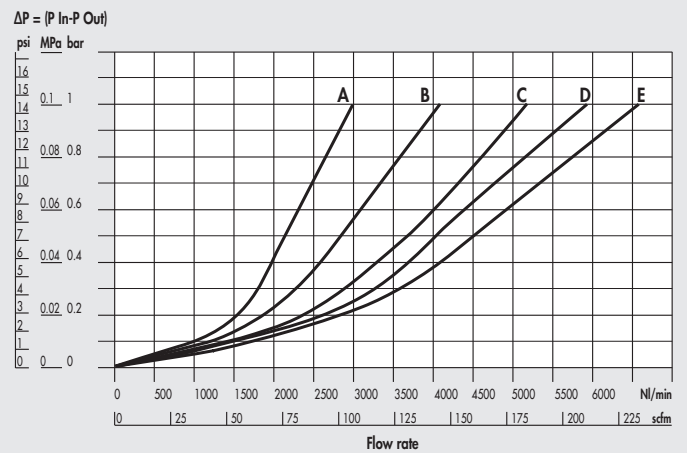

A = 2.5 bar - 0.25 MPa - 36 psi
 B = 4 bar - 0.4 MPa - 58 psi

C = 6.3 bar - 0.63 MPa - 91 psi
 D = 8 bar - 0.8 MPa - 116 psi

E = 10 bar - 1 MPa - 145 psi

DIMENSIONS

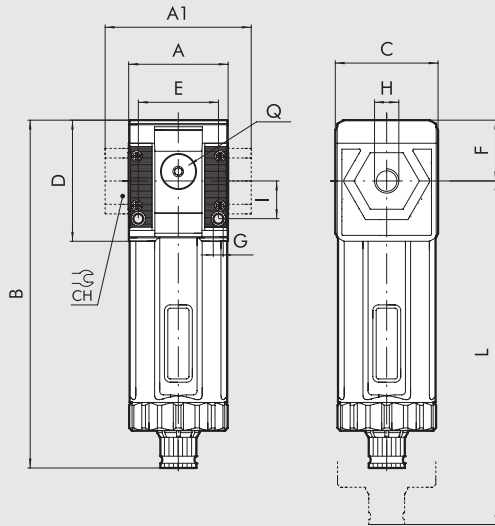

	SIZE 1			SIZE 2			
	1/8"	1/4"	3/8"	3/8"	1/2"	3/4"	1"
H (threaded port)	1/8"	1/4"	3/8"	3/8"	1/2"	3/4"	1"
A	42			61			
A1	-	-	44	-	-	95	95
B	RMSA 148 RA 152			178 182			
C	44			61			
CH	-			-	-	32	36
D	51.5			70.5			
E	33.5			47.5			
F	25.8			38.2			
G	Hole for M4 screws			Hole for M5 screws			
I	16			22.5			
L	RMSA 202 RA 206			245 249			
Q (no. 2 additional air takes-off)	1/8"			1/4"			

KEY TO CODES

56	1	1	F	10	1
SYNTESI	SIZE	THREADED INPUT CONNECTION	ELEMENT	DEGREE OF FILTRATION AND TYPE OF CONDENSATE DRAIN	THREADED OUTPUT CONNECTION
56 Syntesi anti-corrosion	1 Size 1	0 Without bushing 1 1/8" port 2 1/4" port 3 3/8" port	F Filter	10 5 µm RMSA 20 20 µm RMSA 30 50 µm RMSA 40 5 µm RA 50 20 µm RA 60 50 µm RA	0 Without bushing 1 1/8" port 2 1/4" port 3 3/8" port
	2 Size 2	0 Without bushing 3 3/8" port 4 1/2" port 5 3/4" port 6 1" port			0 Without bushing 3 3/8" port 4 1/2" port 5 3/4" port 6 1" port

RMSA: drain with manual condensate discharge and automatic discharge at zero pressure.
RA: automatic drain with condensate discharge, independent of pressure and flow rate.

PURCHASE ORDER CODES HAVING A MORE FREQUENT USE

N.B. Besides the below mentioned codes, you can order elements composed at your will according to the key to codes.

Code	Description	Code	Description	Code	Description
Syntesi® SY1 FILTER		Syntesi® SY2 FILTER		Syntesi® SY2 FILTER	
5610F100	FIL SY1 5 RMSA without bushings	5620F100	FIL SY2 5 RMSA without bushings	5626F106	FIL SY2 1 5 RMSA
5610F200	FIL SY1 20 RMSA without bushings	5620F200	FIL SY2 20 RMSA without bushings	5626F206	FIL SY2 1 20 RMSA
5610F400	FIL SY1 5 RA without bushings	5620F400	FIL SY2 5 RA without bushings	5626F406	FIL SY2 1 5 RA
5610F500	FIL SY1 20 RA without bushings	5620F500	FIL SY2 20 RA without bushings	5626F506	FIL SY2 1 20 RA
5611F101	FIL SY1 1/8 5 RMSA	5623F103	FIL SY2 3/8 5 RMSA		
5611F201	FIL SY1 1/8 20 RMSA	5623F203	FIL SY2 3/8 20 RMSA		
5611F401	FIL SY1 1/8 5 RA	5623F403	FIL SY2 3/8 5 RA		
5611F501	FIL SY1 1/8 20 RA	5623F503	FIL SY2 3/8 20 RA		
5612F102	FIL SY1 1/4 5 RMSA	5624F104	FIL SY2 1/2 5 RMSA		
5612F202	FIL SY1 1/4 20 RMSA	5624F204	FIL SY2 1/2 20 RMSA		
5612F402	FIL SY1 1/4 5 RA	5624F404	FIL SY2 1/2 5 RA		
5612F502	FIL SY1 1/4 20 RA	5624F504	FIL SY2 1/2 20 RA		
5613F103	FIL SY1 3/8 5 RMSA	5625F105	FIL SY2 3/4 5 RMSA		
5613F203	FIL SY1 3/8 20 RMSA	5625F205	FIL SY2 3/4 20 RMSA		
5613F403	FIL SY1 3/8 5 RA	5625F405	FIL SY2 3/4 5 RA		
5613F503	FIL SY1 3/8 20 RA	5625F505	FIL SY2 3/4 20 RA		

NOTE

Anti-corrosion version

5X-----

Example

5X11F101 FIL SY1 1/8 5 RMSA anti-corrosion

The job of the filter purifier is to separate liquid and solid particles dispersed in the compressed air with a high degree of efficiency. This separation is achieved by means of a special filtering element called a "coalescence cartridge".

It is particularly indicated for eliminating traces of oil present in the compressed air. The air flow rate must remain below the maximum values to achieve the desired degree of purification. Beyond this value, there may be a decline in the quality of air from the purifier.

On the front and back there is a port (1/8" for size 1 and 1/4" for size 2) that can be used with pressure gauges, pressure switches or as an additional air intake. **The air taken from here is not purified.**



TECHNICAL DATA	DEP SY1			DEP SY2			
	1/8"	1/4"	3/8"	3/8"	1/2"	3/4"	1"
Threaded port	1/8"	1/4"	3/8"	3/8"	1/2"	3/4"	1"
Degree of filtration	0.01 - output air purity class ISO8573-1: 1.7.2						
Max. input pressure	bar			bar			
	MPa			MPa			
Suggested flow rate at 6.3 bar (0.63 MPa; 91 psi)	NL/min			NL/min			
	scfm			scfm			
Maximun suggested flow rate	See graph on the next page						
Min/max temperature at 10 bar; 1 MPa; 145 psi	°C			°C			
	From -10 to +50			From -10 to +50			
Weight	194	189	180	483	456	452	440
Condensate drain	RMSA: drain with manual condensate discharge and automatic discharge at zero pressure						
Fluid	Compressed air or other inert gases						
Bowl capacity	cm ³			cm ³			
Mounting position	Vertical			Vertical			
Port for additional air take-off (not purified air)	1/8", front and rear			1/4", front and rear			
Additional air take-off flow rate at 6.3 bar (0.63 MPa; 91 psi) ΔP 1 bar (0.1 MPa; 14 psi)	NL/min			NL/min			
	scfm			scfm			
Wall fixing screws	No. 2 M4 screws			No. 2 M5 screws			
Notes on use	It is advisable to mount a 5 μm filter upstream of the purifier to retain solid particles						

COMPONENTS

- ① Technopolymer depurator body
- ② IN/OUT bushing made of OT58 nickel-plated brass or passivated aluminium for 3/4" - 1"
- ③ Coalescence cartridge
- ④ Technopolymer cartridge support
- ⑤ Drain (RMSA)
- ⑥ Technolpolymer plate
- ⑦ NBR o-ring gaskets
- ⑧ Clear technopolymer bowl

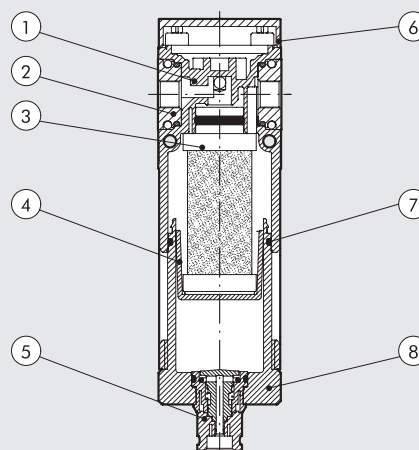

HOW THE COALESCENCE CARTRIDGE WORKS

Air from the mains – full of impurities – flows into the coalescence cartridge and then passes through the crossed micro-fibres that make up the cartridge. During this movement the liquid particles come into contact with the crossed micro-fibres and adhere to them. Due to the air pressure and gravity they join up with other micro-drops at each cross-over point and gradually increase in volume, leading to the physical phenomenon called coalescence. When they stop moving, the drops deposit on the outside of the cartridge, from which they detach and drop to the bottom. Since the volume of liquid leaving the cartridge is exactly the same as the drops arriving, the coalescence cartridge ought to work indefinitely. Solid particles are caught with the same efficiency but, unlike drops, they are not drained out and clog the cartridge. To get round this problem, it is necessary to mount a 5µm prefilter before the fine oil filter to separate the solid particles first.

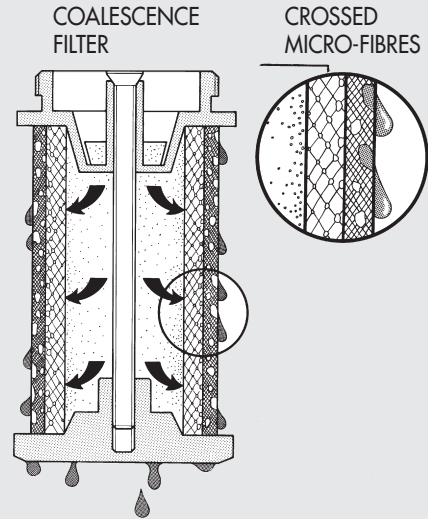

FLOW CHARTS

DEP Syntesi® SY1 1/8"

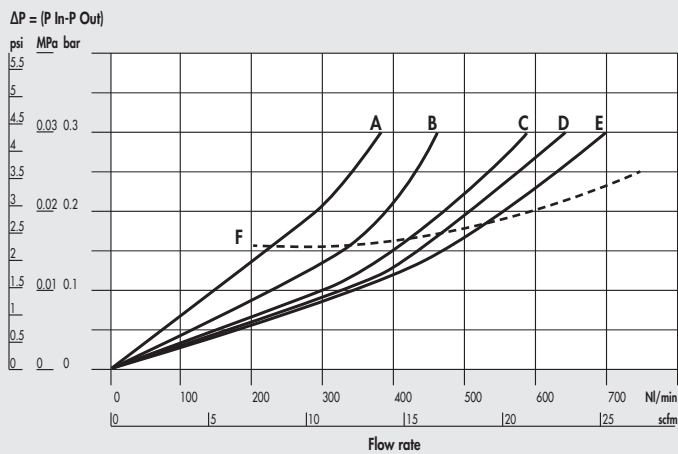

DEP Syntesi® SY1 1/4"

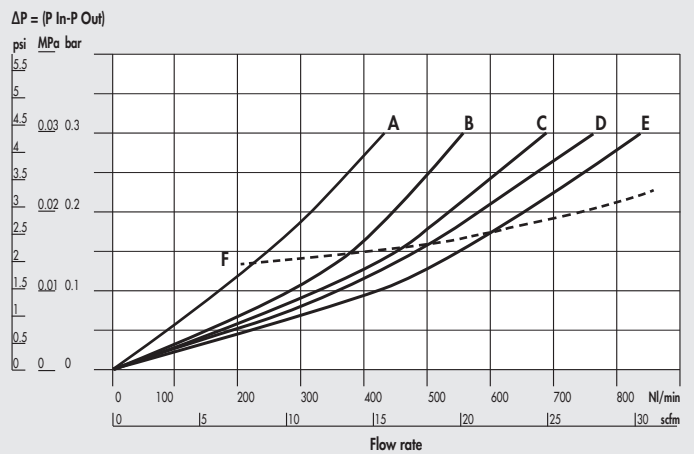

DEP Syntesi® SY1 3/8"

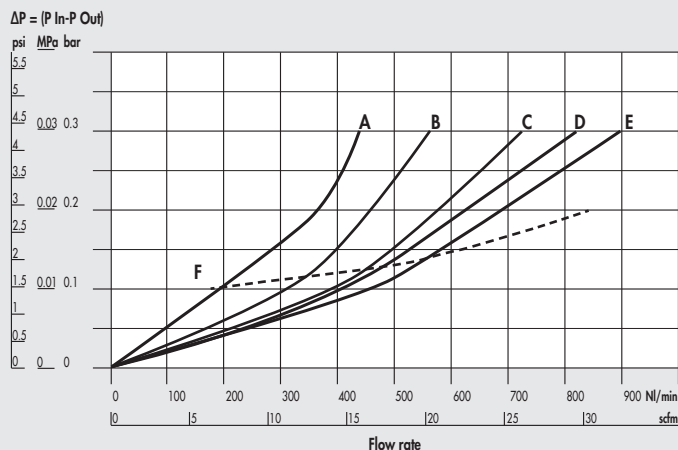

DEP Syntesi® SY2 3/8"

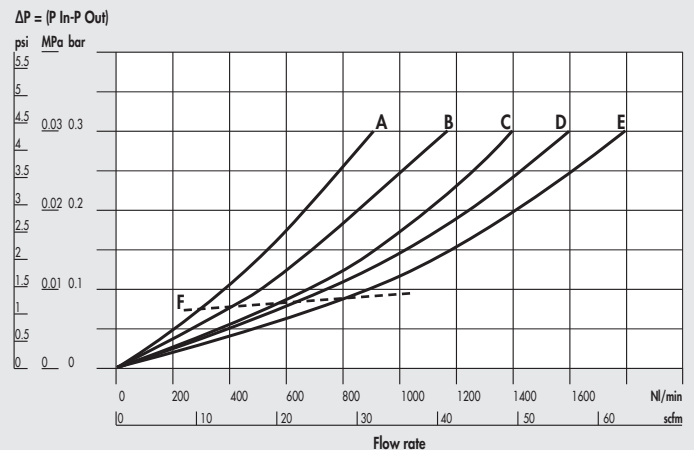

DEP Syntesi® SY2 1/2"

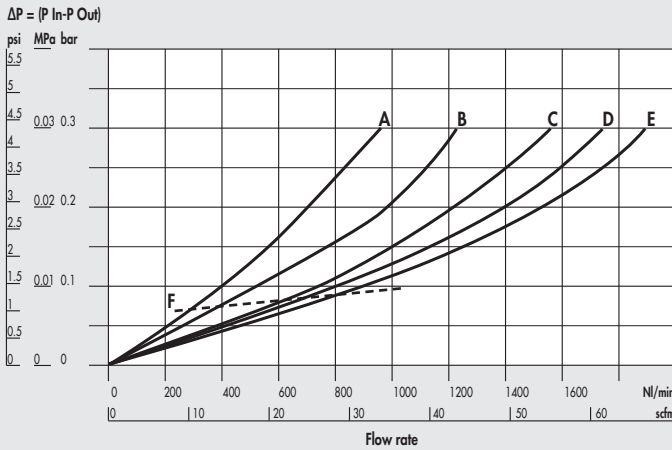

DEP Syntesi® SY2 3/4" - 1"

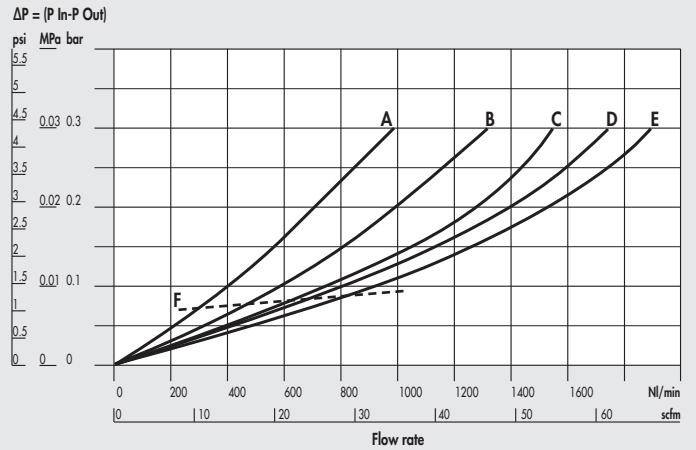

A = 2.5 bar - 0.25 MPa - 36 psi
B = 4 bar - 0.4 MPa - 58 psi

C = 6.3 bar - 0.63 MPa - 91 psi
D = 8 bar - 0.8 MPa - 116 psi

E = 10 bar - 1 MPa - 145 psi
F = max suggested flow

DIMENSIONS

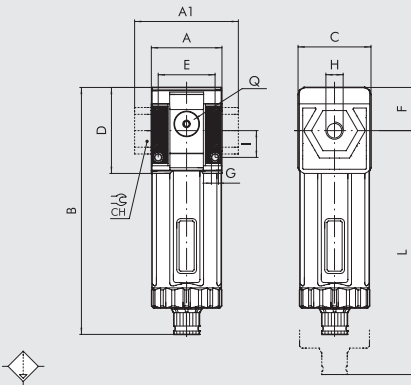

	SIZE 1			SIZE 2		
H (threaded port)	1/8"	1/4"	3/8"	3/8"	1/2"	3/4" 1"
A	42			61		
A1	-	-	44	-	-	95 95
B	RMSA 148			178		
C	44			61		
CH	-			-	-	32 36
D	51.5			70.5		
E	33.5			47.5		
F	25.8			38.2		
G	Hole for M4 screws			Hole for M5 screws		
I	16			22.5		
L	RMSA 202			245		
Q (no. 2 additional air takes-off)	1/8"			1/4"		

KEY TO CODES

56	1	1	D	10	1
SYNTESI	SIZE	THREADED INPUT CONNECTION	ELEMENT	TYPE	THREADED OUTPUT CONNECTION
56 Syntesi 5X Syntesi anti-corrosion	1 Size 1 2 Size 2	0 Without bushing 1 1/8" port 2 1/4" port 3 3/8" port 0 Without bushing 3 3/8" port 4 1/2" port 5 3/4" port 6 1" port	D Depurator	10 RMSA	0 Without bushing 1 1/8" port 2 1/4" port 3 3/8" port 0 Without bushing 3 3/8" port 4 1/2" port 5 3/4" port 6 1" port

RMSA: drain with manual condensate discharge and automatic discharge at zero pressure.

PURCHASE ORDER CODES HAVING A MORE FREQUENT USE

N.B. Besides the below mentioned codes, you can order elements composed at your will according to the key to codes.

Code	Description	Code	Description
Syntesi® SY1 DEPURATOR		Syntesi® SY2 DEPURATOR	
5610D100	DEP SY1 RMSA without bushings	5620D100	DEP SY2 RMSA without bushings
5611D101	DEP SY1 1/8 RMSA	5623D103	DEP SY2 3/8 RMSA
5612D102	DEP SY1 1/4 RMSA	5624D104	DEP SY2 1/2 RMSA
5613D103	DEP SY1 3/8 RMSA	5625D105	DEP SY2 3/4 RMSA
		5626D106	DEP SY2 1 RMSA

NOTE

Anti-corrosion version

5X-----

Example

5X11D101 DEP SY1 1/8 RMSA anti-corrosion

SYNTESI® ACTIVE CARBON FILTER

Activated-carbon filtering systems achieve the highest standard of purification possible in industrial applications. They eliminate all traces of oils, solvents and hydrocarbons, and remove unpleasant odours. The operating principle uses activated carbon, which absorbs most of the polluting particles in the air thanks to minute holes in the granules of carbon.

On the front and back there is a port (1/8" for size 1 and 1/4" for size 2) that can be used with pressure gauges, pressure switches or as an additional air intake. **The air taken from here is not filtered by the activated-carbon cartridge.**

Cartridge life and efficiency can be increased by using pre-filtered (5µm) and purified (0.01 µm) air.

The cartridge must be replaced at set intervals as there is no difference in load loss between an efficient cartridge and a saturated one.

N.B.: to ensure the performance and duration stated on the data sheet, the load loss (ΔP) must not exceed 75 mbar.



UNITS

Syntesi® ACTIVE CARBON FILTER

TECHNICAL DATA	FIL CA SY1			FIL CA SY2			
	1/8"	1/4"	3/8"	3/8"	1/2"	3/4"	1"
Threaded port							
Residual oil at 20°C *	mg/m ³ 0.003 - output air purity class ISO8573-1: 1.7.1						
Duration of cartridge *	hours 4000			4000			
Max. inlet pressure	bar 15			13			
	MPa 1.5			1.3			
	psi 217			188			
Suggested flow rate at 6.3 bar (0.63 MPa; 91 psi)	NL/min 350			800			
	scfm 12			28			
	N.B.: flow rates higher than the recommended value reduces purification efficiency						
Min/max temperature at 10 bar; 1 MPa; 145 psi	°C From -10 to +50			From -10 to +50			
Weight	g 195	190	181	483	456	452	440
Condensate drain	RMSA: drain with manual condensate discharge and automatic discharge at zero pressure						
Fluid	0.01 µm filtered and deperurated air						
Mounting position	In any position			In any position			
Additional air take-off port (unfiltered air from cartridge CA)	1/8", front and rear			1/4", front and rear			
Additional air take-off flow rate at 6.3 bar	NL/min 500			1500			
(0.63 MPa; 91 psi) ΔP 1 bar (0.1 MPa; 14 psi)	scfm 18			53			
Wall fixing screws	No. 2 M4 screws			No. 2 M5 screws			
Notes on use	Upstream it's necessary to mount a coalescence filter deperurator of 0.01 µm.						
	* if the load loss of 75 mbar is not exceeded						

COMPONENTS

- ① Technopolymer deperurator body
- ② IN/OUT bushing made of OT58 nickel-plated brass or passivated aluminium for 3/4" - 1"
- ③ Active carbon cartridge
- ④ Technopolymer cartridge support
- ⑤ Drain (RMSA)
- ⑥ Technopolymer plate
- ⑦ NBR o-ring gasket
- ⑧ Clear technopolymer bowl

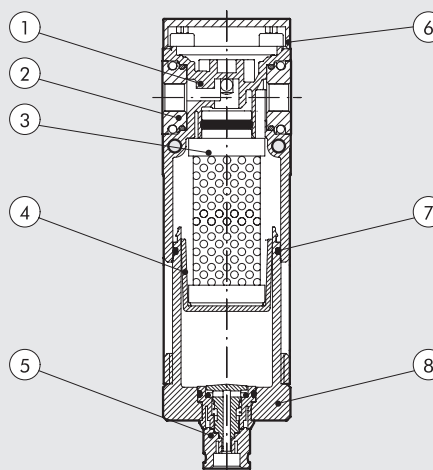

FLOW CHARTS

FIL CA Syntesi® SY1 1/8"

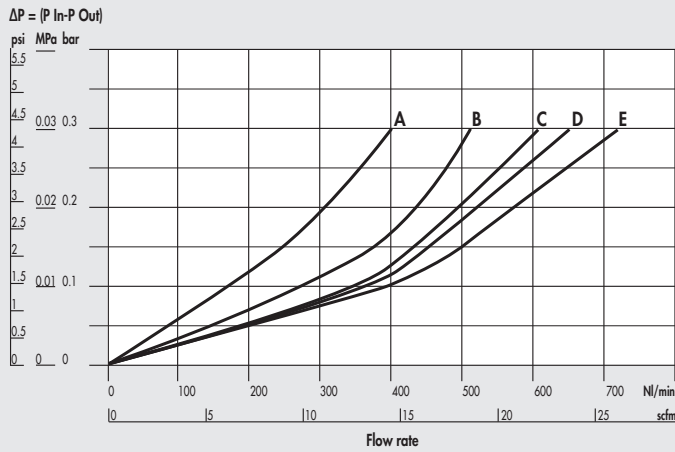

FIL CA Syntesi® SY1 1/4"

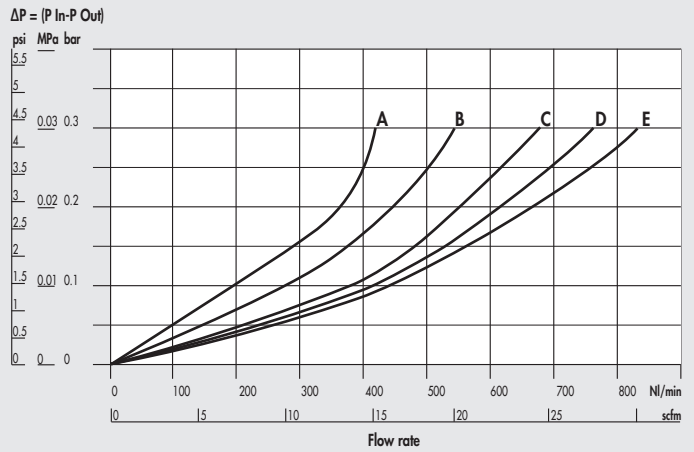

FIL CA Syntesi® SY1 3/8"

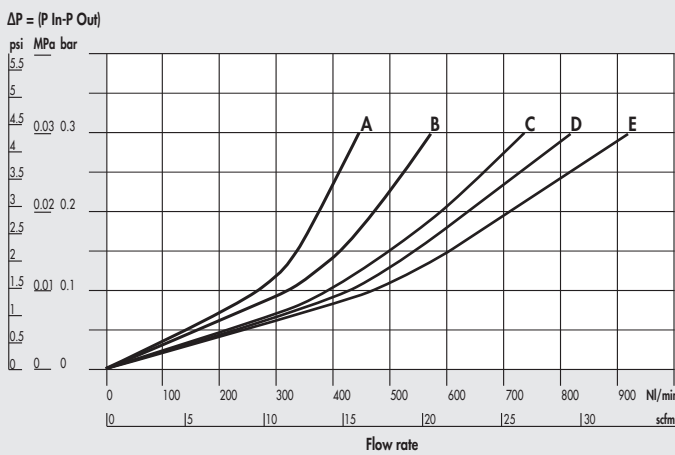

FIL CA Syntesi® SY2 3/8"

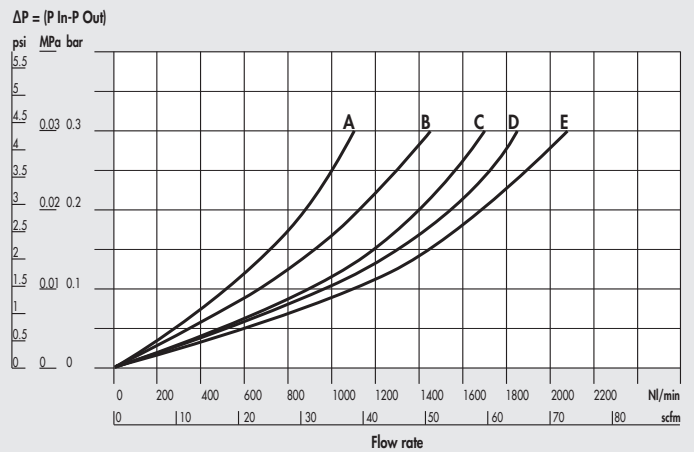

FIL CA Syntesi® SY2 1/2"

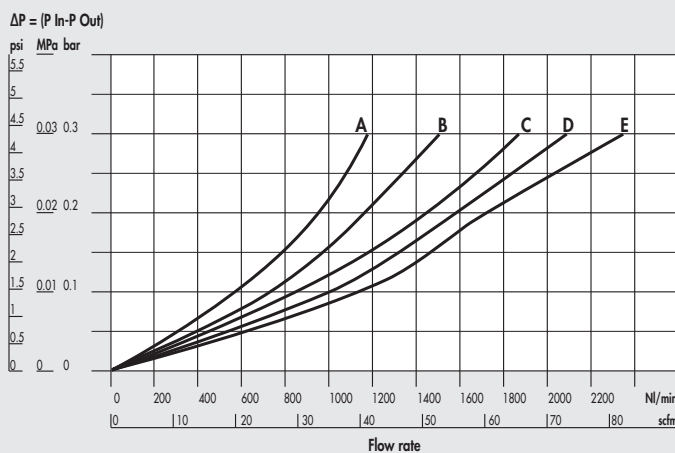

FIL CA Syntesi® SY2 3/4" - 1"

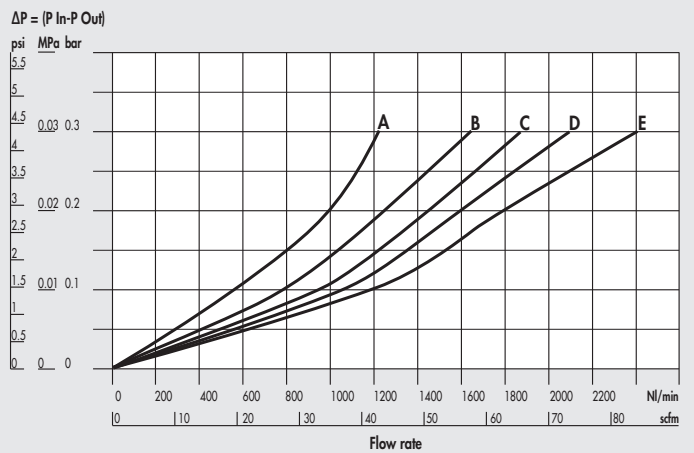

A = 2.5 bar - 0.25 MPa - 36 psi
 B = 4 bar - 0.4 MPa - 58 psi

C = 6.3 bar - 0.63 MPa - 91 psi
 D = 8 bar - 0.8 MPa - 116 psi

E = 10 bar - 1 MPa - 145 psi

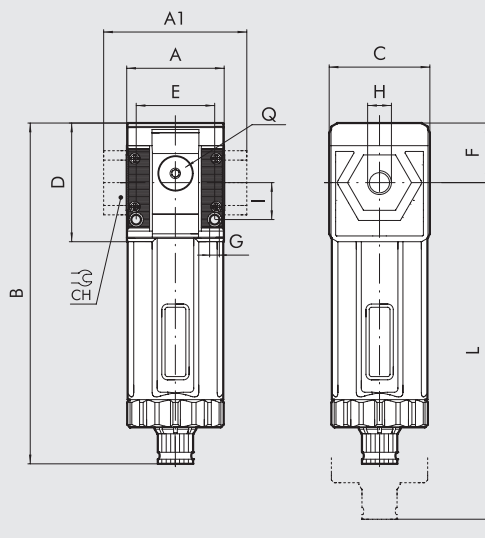
DIMENSIONS

	SIZE 1			SIZE 2			
	1/8"	1/4"	3/8"	3/8"	1/2"	3/4"	1"
H (threaded port)	1/8"	1/4"	3/8"	3/8"	1/2"	3/4"	1"
A	42			61			
A1	-	-	44	-	-	95	95
B	RMSA 148			178			
C	44			61			
CH	-			-	-	32	36
D	51.5			70.5			
E	33.5			47.5			
F	25.8			38.2			
G	Hole for M4 screws			Hole for M5 screws			
I	16			22.5			
L	RMSA 202			245			
Q (no. 2 additional air takes-off)	1/8"			1/4"			

KEY TO CODES

56	1	1	C	10	1
SYNTESI	SIZE	THREADED INPUT CONNECTION	ELEMENT	TYPE	THREADED OUTPUT CONNECTION
56 Syntesi anti-corrosion	1 Size 1	0 Without bushing 1 1/8" port 2 1/4" port 3 3/8" port	C Active carbon filter	10 RMSA	0 Without bushing 1 1/8" port 2 1/4" port 3 3/8" port
	2 Size 2	0 Without bushing 3 3/8" port 4 1/2" port 5 3/4" port 6 1" port			0 Without bushing 3 3/8" port 4 1/2" port 5 3/4" port 6 1" port

RMSA: Drain with manual condensate discharge and automatic discharge at zero pressure.

PURCHASE ORDER CODES HAVING A MORE FREQUENT USE

N.B. Besides the below mentioned codes, you can order elements composed at your will according to the key to codes.

Code	Description	Code	Description	NOTE
Syntesi® SY1 ACTIVE CARBON FILTER		Syntesi® SY2 ACTIVE CARBON FILTER		Anti-corrosion version
5610C100	AC SY1 RMSA without bushings	5620C100	AC SY2 RMSA without bushings	5X -----
5611C101	AC SY1 1/8 RMSA	5623C103	AC SY2 3/8 RMSA	Example
5612C102	AC SY1 1/4 RMSA	5624C104	AC SY2 1/2 RMSA	5X11C101 AC SY1 1/8 RMSA anti-corrosion
5613C103	AC SY1 3/8 RMSA	5625C105	AC SY2 3/4 RMSA	
		5626C106	AC SY2 1 RMSA	

Syntesi® pressure regulator is based on the rolling diaphragm principle, which offers numerous advantages compared to systems using a flat diaphragm:

- Increased stroke, allowing wider valve aperture and hence greater flow rate.
- Decreased dynamic and pick-up friction, and hence quicker response and enhanced sensitivity.
- Greater accuracy in maintaining the pressure setting, both with both variable flow rates and different supply pressures.

The regulator includes a compensation system that keeps the pressure setting virtually constant, even when the upstream pressure changes. This is achieved mainly by the design of the valve, which is pneumatically balanced.

If the downstream pressure rises above the threshold value, the air is discharged (relief valve) until it drops below the maximum value.

A special device relieves downstream pressure rapidly when the upstream pressure drops to zero. This means the regulator can be positioned between a valve and a cylinder because the air can flow in both directions, towards the cylinder with regulated pressure, or return towards the valve during relief.

The knob is the push-lock type – once the pressure has been set, press it and it locks in position. In this position you can pull out the plate and attach two padlocks on size 1 or three padlocks on size 2 in order to avoid possible tampering. On the front and back there is a port (1/8" for size 1 and 1/4" size 2) that can be used with pressure gauges, pressure switches or as an additional regulated air intake.



TECHNICAL DATA	REG SY1			REG SY2			
	1/8"	1/4"	3/8"	3/8"	1/2"	3/4"	1"
Threaded port							
Max. inlet pressure							
		bar					
		MPa					
		psi					
Flow rate at 6.3 bar (0.63 MPa; 91 psi) ΔP 0.5 bar (0.5 MPa; 7 psi)	Nl/min	570	1600	2900	3000	4300	4700
(inlet pressure 10 bar)	scfm	20	57	103	106	152	166
Flow rate at 6.3 bar (0.63 MPa; 91 psi) ΔP 1 bar (0.1 MPa; 14 psi)	Nl/min	1200	2800	3350	5300	7400	7600
(inlet pressure 10 bar)	scfm	42	99	119	188	261	267
Relief valve flow rate at 6.3 bar (0.63 MPa; 91 psi)	Nl/min		70			100	
	scfm		2.5			3.5	
Min/max temperature at 10 bar; 1 MPa; 145 psi	°C	From -10 to +50			From -10 to +50		
Full outflow with zero inlet pressure		Included					
Padlockable knob		Included					
Upstream pressure compensation		Included, via balanced valve					
Weight	g	193	188	179	546	519	515 503
Fluid		Compressed air or other inert gases					
Mounting position		In any position					
Additional air take-off, for pressure gauges or fittings		1/8", front and rear			1/4", front and rear		
Additional air take-off flow rate at 6.3 bar	Nl/min	500			1400		
(0.63 MPa; 91 psi) ΔP 1 bar (0.1 MPa; 14 psi)	scfm	18			50		
Wall fixing screws		No. 2 M4 screws			No. 2 M5 screws		
Notes on use		The pressure must always be set upwards. For increased sensitivity, use a pressure regulator with a rated pressure as close as possible to the required value. On request version without overpressure exhaust					

COMPONENTS

- ① Technopolymer adjusting knob
- ② Technopolymer bell
- ③ Steel adjusting spring (with Geomet® treatment for anti-corrosion version)
- ④ Technopolymer flange
- ⑤ Rolling diaphragm
- ⑥ IN/OUT bushing made of OT58 nickel-plated brass or passivated aluminium for 3/4" - 1"
- ⑦ Technopolymer regulator body
- ⑧ OT58 brass valve, with NBR vulcanized gasket
- ⑨ Stainless steel valve spring
- ⑩ Galvanised steel plate for knob locking (stainless steel for anti-corrosion version)
- ⑪ OT58 brass adjusting screw
- ⑫ Technopolymer ring nut
- ⑬ Technopolymer plate
- ⑭ Technopolymer rod
- ⑮ NBR o-ring gasket
- ⑯ Technopolymer plug

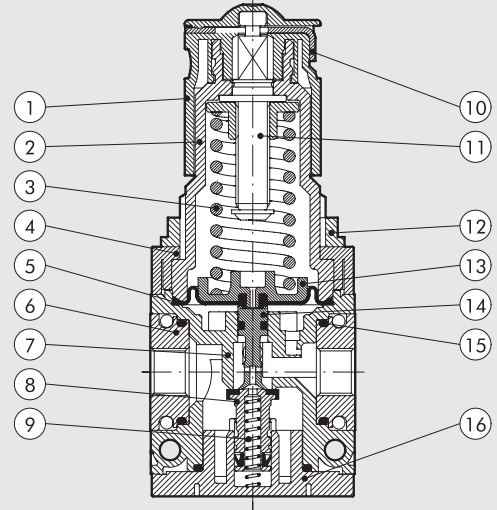

FLOW CHARTS

REG Syntesi® SY1 1/8"

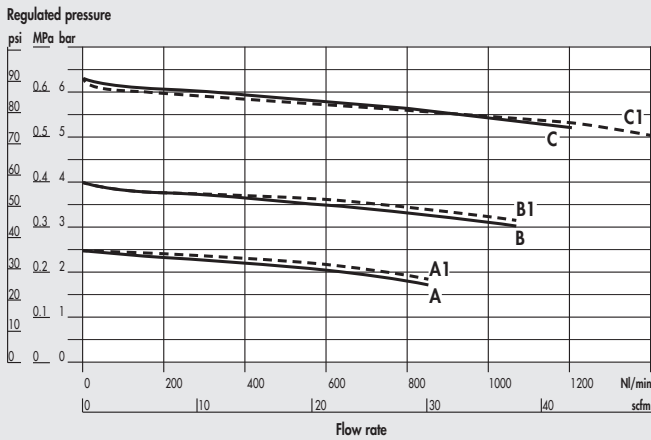

REG Syntesi® SY1 1/4"

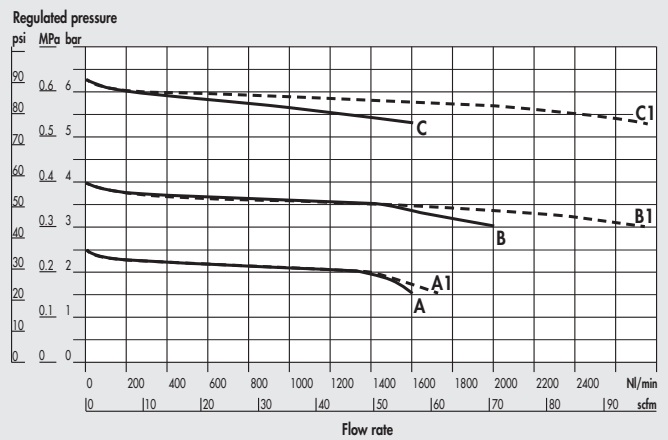

REG Syntesi® SY1 3/8"

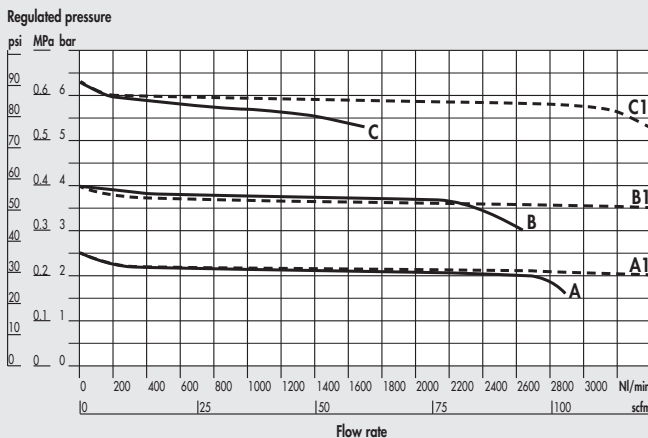

REG Syntesi® SY2 3/8"

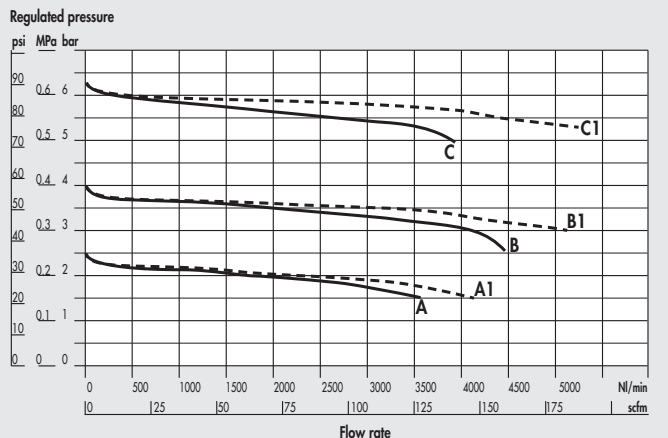

REG Syntesi® SY2 1/2"

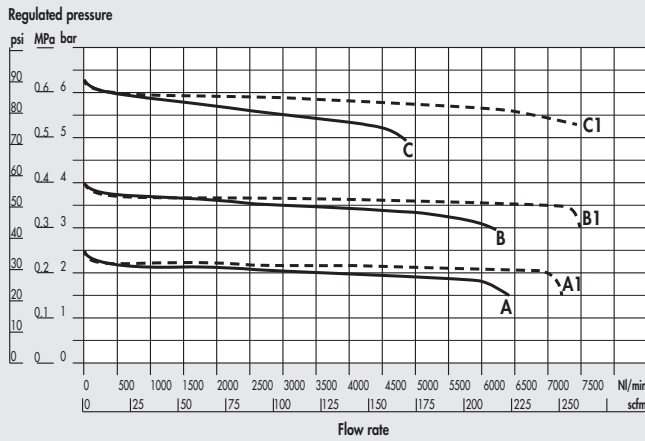

A = P In 7 bar - P Out 2.5 bar
B = P In 7 bar - P Out 4 bar

C = P In 7 bar - P Out 6.3 bar
A1 = P In 10 bar - P Out 2.5 bar

REG Syntesi® SY2 3/4" - 1"

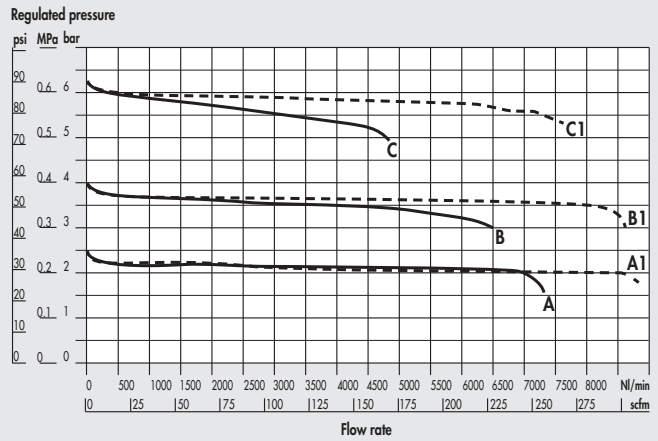

B1 = P In 10 bar - P Out 4 bar
C1 = P In 10 bar - P Out 6.3 bar

DIMENSIONS

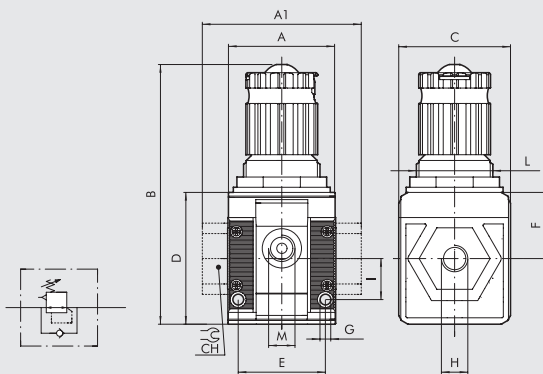

	SIZE 1			SIZE 2			
H (threaded port)	1/8"	1/4"	3/8"	3/8"	1/2"	3/4"	1"
A	42			61			
A1	-	-	44	-	-	95	95
B	102			142			
C	44			61			
CH	-			-	-	32	36
D	51.5			70.5			
E	33.5			47.5			
F	25.8			38.2			
G	Hole for M4 screws			Hole for M5 screws			
I	16			22.5			
L	M30x1.5			M38x2			
M (pressure gauge port or air takes-off)	1/8"			1/4"			

KEY TO CODES

56	1	1	R	14	1
SYNTESI	SIZE	THREADED INPUT CONNECTION	ELEMENT	SETTING RANGE	THREADED OUTPUT CONNECTION
56 Syntesi 5X Syntesi anti-corrosion	1 Size 1 2 Size 2	0 Without bushing 1 1/8" port 2 1/4" port 3 3/8" port 0 Without bushing 3 3/8" port 4 1/2" port 5 3/4" port 6 1" port	R Pressure regulator	● 10 0 ÷ 2 bar ● 12 0 ÷ 4 bar 14 0 ÷ 8 bar 16 0 ÷ 12 bar	0 Without bushing 1 1/8" port 2 1/4" port 3 3/8" port 0 Without bushing 3 3/8" port 4 1/2" port 5 3/4" port 6 1" port

● Not available in the anti-corrosion version.

PURCHASE ORDER CODES HAVING A MORE FREQUENT USE

N.B. Besides the below mentioned codes, you can order elements composed at your will according to the key to codes.

Code	Description	Code	Description	Code	Description
Syntesi® SY1 REGULATOR		Syntesi® SY2 REGULATOR		Syntesi® SY2 REGULATOR	
5610R140	REG SY1 08 without bushings	5620R140	REG SY2 08 without bushings	5626R146	REG SY2 1 08
5610R160	REG SY1 012 without bushings	5620R160	REG SY2 012 without bushings	5626R166	REG SY2 1 012
5611R141	REG SY1 1/8 08	5623R143	REG SY2 3/8 08	NOTE	
5611R161	REG SY1 1/8 012	5623R163	REG SY2 3/8 012	Anti-corrosion version	
5612R142	REG SY1 1/4 08	5624R144	REG SY2 1/2 08	5X-----	
5612R162	REG SY1 1/4 012	5624R164	REG SY2 1/2 012	Example	
5613R143	REG SY1 3/8 08	5625R145	REG SY2 3/4 08	5X11R141 REG SY1 1/8 08 anti-corrosion	
5613R163	REG SY1 3/8 012	5625R165	REG SY2 3/4 012		

SYNTESI® IN-SERIES REGULATOR

The in-series regulator is used to take air at a set pressure from the ports on the front and back of the body, while the pneumatic inlet and outlet ports are connected directly.

It is possible for instance to assemble several regulators side by side, all supplied at the same pressure, and obtain different regulated pressures, regardless of the pressure of the previous module.

The in-series regulator uses the same construction principles as the standard regulator, so the advantages are the same, such as compensation for upstream pressure changes, relief valve, rapid relief of the downstream pressure and a padlockable push-lock knob.



TECHNICAL DATA	IN-SERIES REGULATOR SY1			IN-SERIES REGULATOR SY2				
	1/8"	1/4"	3/8"	3/8"	1/2"	3/4"	1"	
Threaded inlet port, through	1/8"	1/4"	3/8"	3/8"	1/2"	3/4"	1"	
Utility threaded port		1/8"				1/4"		
Max. input pressure	bar			13				
	MPa			1.3				
	psi			188				
Flow rate at 6.3 bar (0.63 MPa; 91 psi) ΔP 0.5 bar (0.05 MPa; 7 psi)	Nl/min			540				
	scfm			19				
Flow rate at 6.3 bar (0.63 MPa; 91 psi) ΔP 1 bar (0.1 MPa; 14 psi)	Nl/min			1000				
	scfm			35				
Relief valve flow rate at 6.3 bar (0.63 MPa; 91 psi)	Nl/min			100				
	scfm			3.5				
Min/max temperature at 10 bar; 1 MPa; 145 psi	°C			From -10 to +50				
Full outflow with zero inlet pressure				Included				
Padlockable knob				Included				
Upstream pressure compensation				Included, via balanced valve				
Weight	g	193	188	179	546	519	515	503
Fluid	Compressed air or other inert gases							
Mounting position	In any position							
Wall fixing screws	No. 2 M4 screws			No. 2 M5 screws				
Notes on use	The pressure must always be set upwards. For increased sensitivity, use a pressure regulator with a rated pressure as close as possible to the required value. On request version without overpressure exhaust							

COMPONENTS

- ① Technopolymer adjusting knob
- ② Technopolymer bell
- ③ Steel adjusting spring (with Geome® treatment for anti-corrosion version)
- ④ Technopolymer flange
- ⑤ Rolling diaphragm
- ⑥ IN/OUT bushing made of OT58 nickel-plated brass or passivated aluminium for 3/4" - 1"
- ⑦ Technopolymer body
- ⑧ OT58 brass valve, with NBR vulcanized gasket
- ⑨ Stainless steel valve spring
- ⑩ Galvanised steel plate for knob locking (stainless steel for anti-corrosion version)
- ⑪ OT58 brass adjusting screw
- ⑫ Technopolymer ring nut
- ⑬ Technopolymer plate
- ⑭ Technopolymer rod
- ⑮ NBR o-ring gaskets
- ⑯ Technopolymer plug

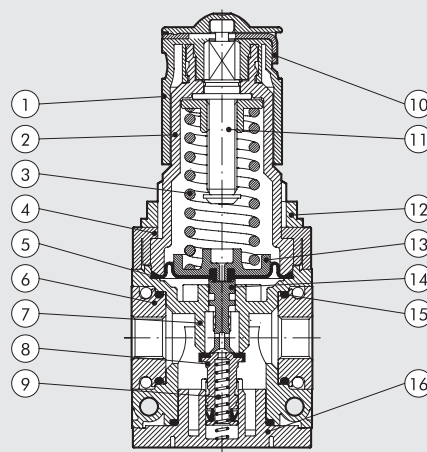

FLOW CHARTS

IN-SERIES REGULATOR Syntesi® SY1 1/4"-1/8"-3/8"

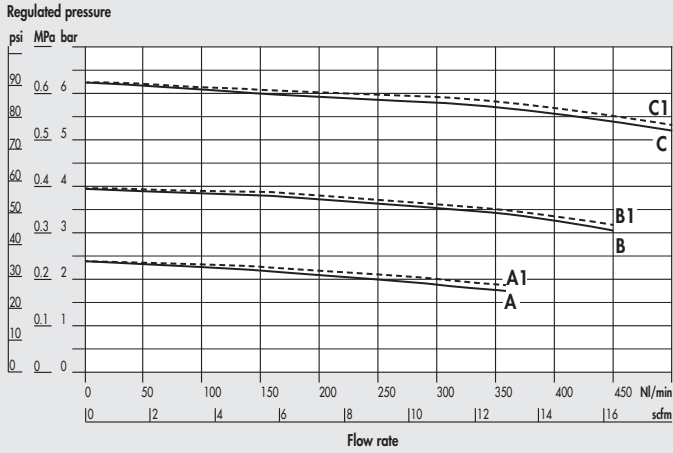

IN-SERIES REGULATOR Syntesi® SY2 3/8" - 1/2" - 3/4" - 1"

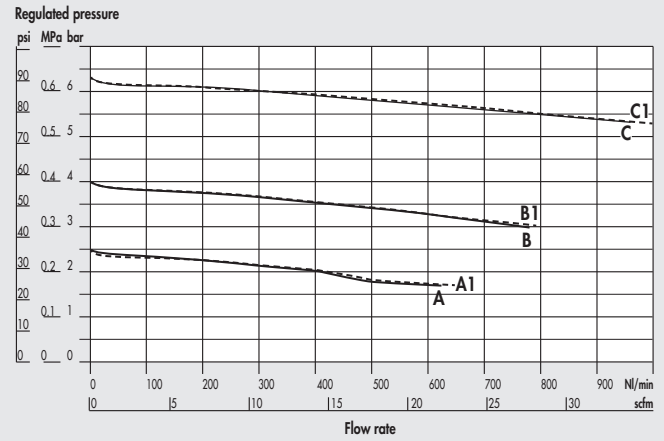

A = P In 7 bar - P Out 2.5 bar
 B = P In 7 bar - P Out 4 bar
 C = P In 7 bar - P Out 6.3 bar

A1 = P In 10 bar - P Out 2.5 bar
 B1 = P In 10 bar - P Out 4 bar
 C1 = P In 10 bar - P Out 6.3 bar

DIMENSIONS

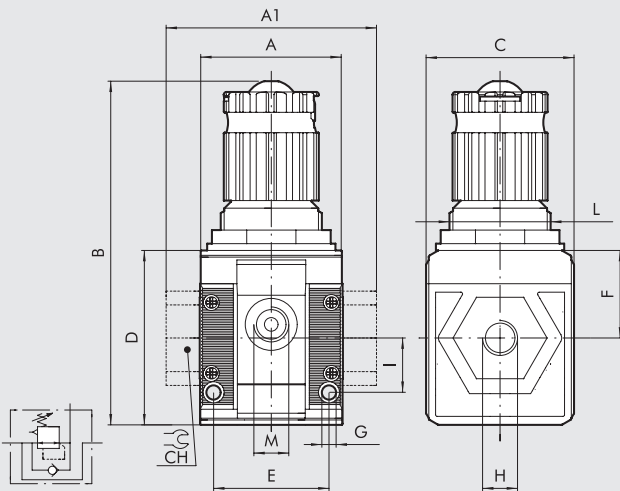

	SIZE 1			SIZE 2			
	1/8"	1/4"	3/8"	3/8"	1/2"	3/4"	1"
H (threaded port)	1/8"	1/4"	3/8"	3/8"	1/2"	3/4"	1"
A		42				61	
A1	-	-	44	-	-	95	95
B		102				142	
C		44				61	
CH		-		-	-	32	36
D		51.5				70.5	
E		33.5				47.5	
F		25.8				38.2	
G		Hole for M4 screws			Hole for M5 screws		
I		16				22.5	
L		M30x1.5				M38x2	
M (use)		1/8"				1/4"	

FUNCTION DIAGRAM

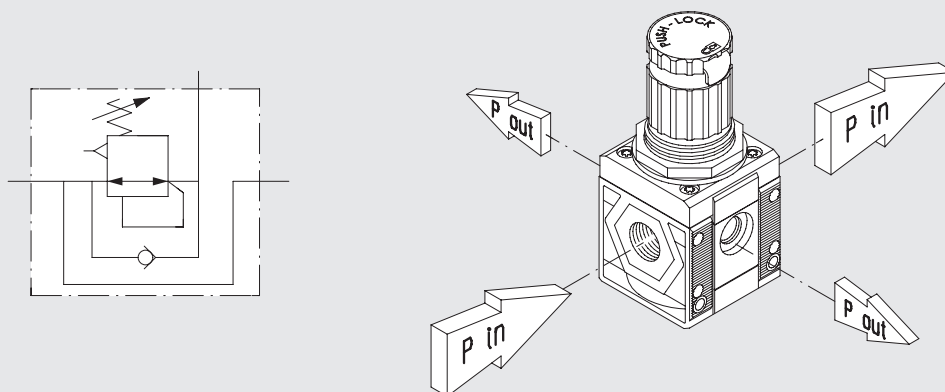

KEY TO CODES

56	1	1	R	24	1
SYNTESI	SIZE	THREADED INPUT CONNECTION	ELEMENT	IN-SERIES REGULATOR SETTING RANGE	THREADED OUTPUT CONNECTION
56 Syntesi 5X Syntesi anti-corrosion	1 Size 1 <hr/> 2 Size 2	0 Without bushing 1 1/8" port 2 1/4" port 3 3/8" port <hr/> 0 Without bushing 3 3/8" port 4 1/2" port 5 3/4" port 6 1" port	R Pressure regulator	● 20 0 to 2 bar ● 22 0 to 4 bar 24 0 to 8 bar 26 0 to 12 bar	0 Without bushing 1 1/8" port 2 1/4" port 3 3/8" port <hr/> 0 Without bushing 3 3/8" port 4 1/2" port 5 3/4" port 6 1" port

● Not available in the anti-corrosion version.

PURCHASE ORDER CODES HAVING A MORE FREQUENT USE

N.B. Besides the below mentioned codes, you can order elements composed at your will according to the key to codes.

Code	Description	Code	Description	NOTE
Syntesi® SY1 IN-SERIES REGULATOR		Syntesi® SY2 IN-SERIES REGULATOR		NOTE
5610R240	In-series REG SY1 08 without bushings	5620R240	In-series REG SY2 08 without bushings	Anti-corrosion version
5610R260	In-series REG SY1 012 without bushings	5620R260	In-series REG SY2 012 without bushings	5X_-----
5611R241	In-series REG SY1 1/8 08	5623R243	In-series REG SY2 3/8 08	Example
5611R261	In-series REG SY1 1/8 012	5623R263	In-series REG SY2 3/8 012	5X11R241 In-series REG SY1 1/8 08 anti-corrosion
5612R242	In-series REG SY1 1/4 08	5624R244	In-series REG SY2 1/2 08	
5612R262	In-series REG SY1 1/4 012	5624R264	In-series REG SY2 1/2 012	
5613R243	In-series REG SY1 3/8 08	5625R245	In-series REG SY2 3/4 08	
5613R263	In-series REG SY1 3/8 012	5625R265	In-series REG SY2 3/4 012	
		5626R246	In-series REG SY2 1 08	
		5626R266	In-series REG SY2 1 012	

NOTES

This device combines in a single unit the functions of filtration, condensate separation and pressure regulation.

It is made up of the same elements forming the filter and the regulator, so the performance and advantages are the same:

- Separation of condensate and larger liquid and solid particles by centrifugation.
- Two condensate drain options (RMSA and RA).
- 360° visually inspection of the condensate level, via transport spy-holes.
- Rolling diaphragm regulator, allowing maximum precision and flow rate, and minimal friction.
- Compensation for upstream pressure changes.
- Pressure relief valve.
- Quick downstream pressure relief.
- Padlockable push-lock knob.
- Front and rear ports for pressure gauges, pressure switches or, considering the high flow rate, for use as additional filtered and regulated air take-off.

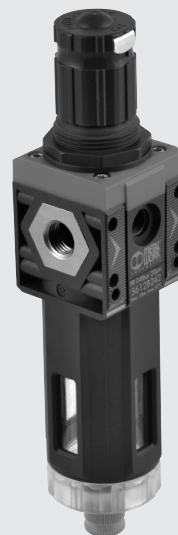

TECHNICAL DATA	FR SY1			FR SY2			
	1/8"	1/4"	3/8"	3/8"	1/2"	3/4"	1"
Threaded port	1/8"	1/4"	3/8"	3/8"	1/2"	3/4"	1"
Degree of filtration	5 (yellow) - output air purity class ISO8573-1: 3.7.4 20 (white) - output air purity class ISO8573-1: 4.7.4 50 (blue) - output air purity class ISO8573-1: 5.7.4						
Max. inlet pressure	bar			bar			
	MPa			MPa			
	psi			psi			
Flow rate at 6.3 bar (0.63 MPa; 91 psi) ΔP 0.5 bar (0.5 MPa; 7 psi)	Nl/min	500	800	2200	3200	4300	5200
(inlet pressure 10 bar)	scfm	18	28	78	113	152	184
Flow rate at 6.3 bar (0.63 MPa; 91 psi) ΔP 1 bar (0.1 MPa; 14 psi)	Nl/min	1300	2000	3000	5800	7200	7400
(inlet pressure 10 bar)	scfm	46	71	106	205	255	262
Relief valve flow rate at 6.3 bar (0.63 MPa; 91 psi)	Nl/min	70			100		
	scfm	2.5			3.5		
Min/max temperature at 10 bar; 1 MPa; 145 psi	°C	From -10 to +50			From -10 to +50		
Full outflow with zero inlet pressure	Included						
Padlockable knob	Included						
Upstream pressure compensation	Included, via balanced valve						
Weight	g	244	239	230	623	596	592
Fluid	Compressed air or other inert gases						
Mounting position	Vertical						
Additional air take-off, for pressure gauges or fittings	1/8", front and rear			1/4", front and rear			
Additional air take-off flow rate at 6.3 bar	Nl/min	500			1400		
(0.63 MPa; 91 psi) ΔP 1 bar (0.1 MPa; 14 psi)	scfm	18			50		
Bowl capacity	cm³	30			70		
Condensate drain	RMSA: drain with manual condensate discharge and automatic discharge at zero pressure RA: automatic drain with condensate discharge, independent of pressure and flow rate Nota d'uso: the maximum input pressure for the RA version must not exceed 10 bar No. 2 M4 screws No. 2 M5 screws						
Wall fixing screws	The pressure must always be set upwards. For increased sensitivity, use a pressure regulator						
Notes on use	with a rated pressure as close as possible to the required value. On request version without overpressure exhaust.						

COMPONENTS

- ① Technopolymer adjusting knob
- ② Technopolymer bell
- ③ Steel adjusting spring (with Geomet® treatment for anti-corrosion version)
- ④ Technopolymer flange
- ⑤ Rolling diaphragm
- ⑥ IN/OUT bushing made of OT58 nickel-plated brass or passivated aluminium for 3/4" - 1"
- ⑦ Technopolymer body
- ⑧ OT58 brass valve, with NBR vulcanized valve
- ⑨ Clear technopolymer bowl
- ⑩ Galvanised steel plate for knob locking (stainless steel for anti-corrosion version)
- ⑪ OT58 brass adjusting screw
- ⑫ Technopolymer ring nut
- ⑬ Technopolymer plate
- ⑭ Technopolymer rod
- ⑮ Stainless steel valve spring
- ⑯ O-ring NBR gaskets
- ⑰ Drain (RMSA)
- ⑱ Sintered HDPE filter cartridge
- ⑲ Technopolymer screen

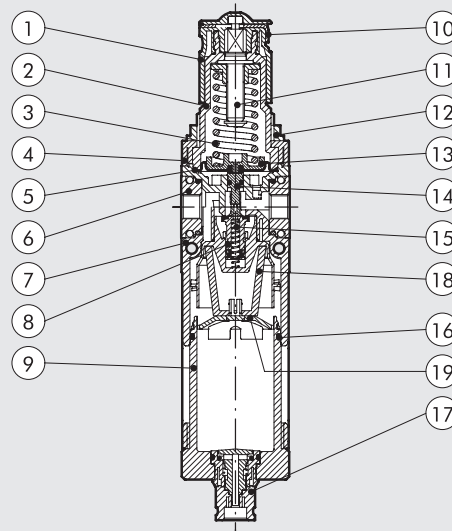

FLOW CHARTS

FR Syntesi® SY1 1/8"

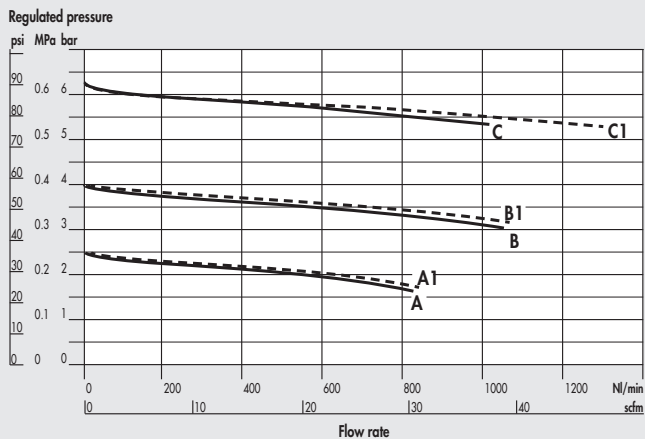

FR Syntesi® SY1 1/4"

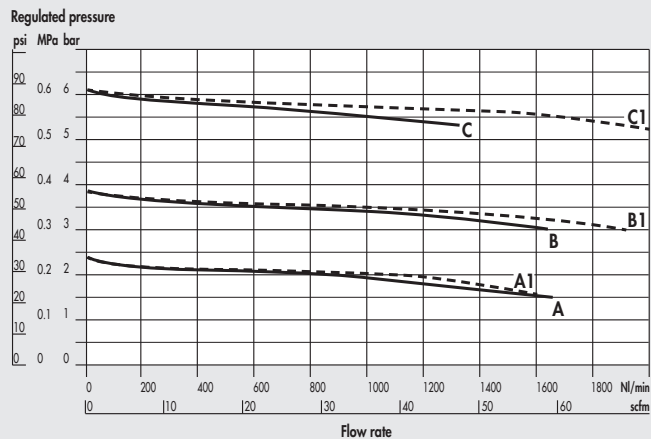

FR Syntesi® SY1 3/8"

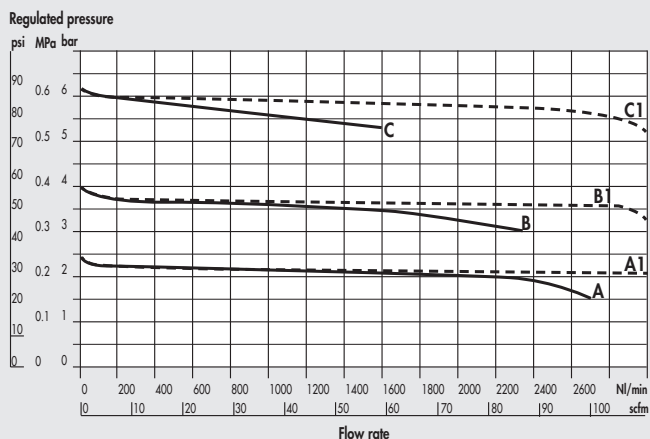

FR Syntesi® SY2 3/8"

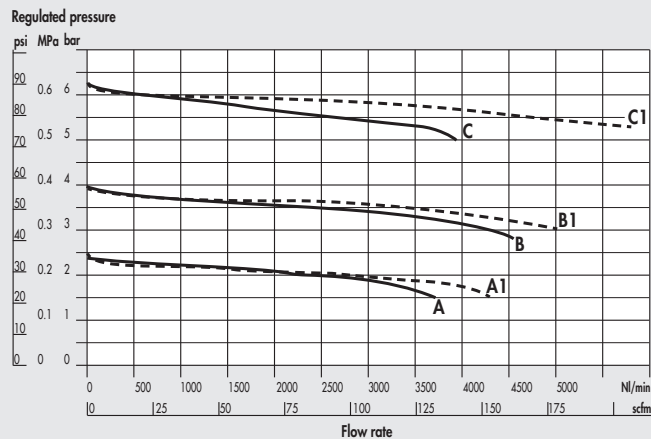

FR Syntesi® SY2 1/2"

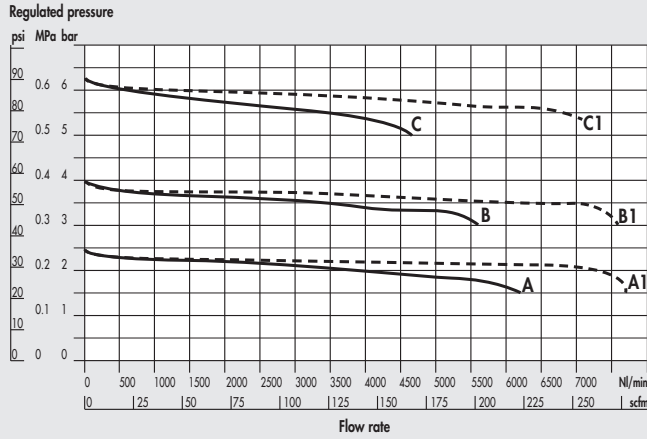

FR Syntesi® SY2 3/4" - 1"

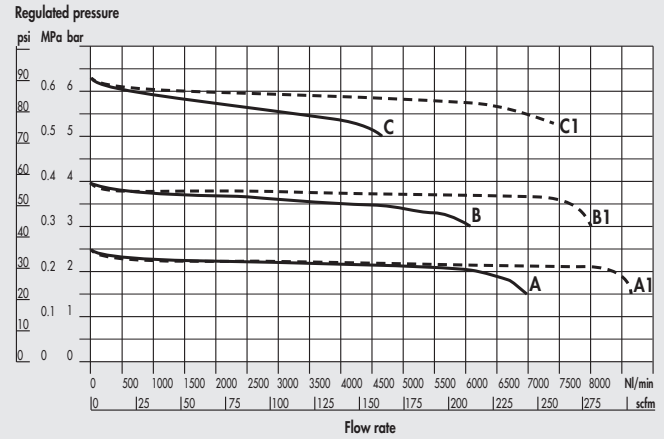

A = P In 7 bar - P Out 2.5 bar
 B = P In 7 bar - P Out 4 bar
 C = P In 7 bar - P Out 6.3 bar

A1 = P In 10 bar - P Out 2.5 bar
 B1 = P In 10 bar - P Out 4 bar
 C1 = P In 10 bar - P Out 6.3 bar

DIMENSIONS

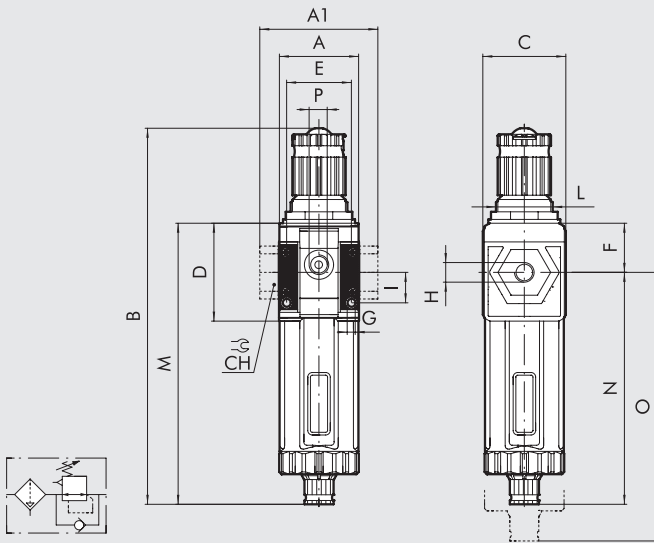

	SIZE 1			SIZE 2			
	1/8"	1/4"	3/8"	3/8"	1/2"	3/4"	1"
H (threaded port)	1/8"	1/4"	3/8"	3/8"	1/2"	3/4"	1"
A	42			61			
A1	-	-	44	-	-	95	95
B	RMSA RA			246 250			
C	44			61			
CH	-			- - 32 36			
D	51.5			70.5			
E	33.5			47.5			
F	25.8			38.2			
G	Hole for M4 screws			Hole for M5 screws			
I	16			22.5			
L	M30x1.5			M38x2			
M	RMSA RA			148 178			
N	RMSA RA			122.2 143.8			
O	RMSA RA			202 249			
P (pressure gauge port or additional air takes-off)	1/8"			1/4"			

NOTES

KEY TO CODES

56	1	1	B	24	1
SYNTESI	SIZE	THREADED INPUT CONNECTION	ELEMENT	DEGREE OF FILTRATION, TYPE OF CONDENSATE DRAIN AND SETTING RANGE	THREADED OUTPUT CONNECTION
56 Syntesi 5X Syntesi anti-corrosion	1 Size 1 <hr/> 2 Size 2	0 Without bushing 1 1/8" port 2 1/4" port 3 3/8" port <hr/> 0 Without bushing 3 3/8" port 4 1/2" port 5 3/4" port 6 1" port	B Filter-regulator	● 10 5 µm, RMSA, 0 to 2 bar ● 20 20 µm, RMSA, 0 to 2 bar ● 30 50 µm, RMSA, 0 to 2 bar ● 40 5 µm, RA, 0 to 2 bar ● 50 20 µm, RA, 0 to 2 bar ● 60 50 µm, RA, 0 to 2 bar ● 12 5 µm, RMSA, 0 to 4 bar ● 22 20 µm, RMSA, 0 to 4 bar ● 32 50 µm, RMSA, 0 to 4 bar ● 42 5 µm, RA, 0 to 4 bar ● 52 20 µm, RA, 0 to 4 bar ● 62 50 µm, RA, 0 to 4 bar 14 5 µm, RMSA, 0 to 8 bar 24 20 µm, RMSA, 0 to 8 bar 34 50 µm, RMSA, 0 to 8 bar 44 5 µm, RA, 0 to 8 bar 54 20 µm, RA, 0 to 8 bar 64 50 µm, RA, 0 to 8 bar 16 5 µm, RMSA, 0 to 12 bar 26 20 µm, RMSA, 0 to 12 bar 36 50 µm, RMSA, 0 to 12 bar 46 5 µm, RA, 0 to 12 bar 56 20 µm, RA, 0 to 12 bar 66 50 µm, RA, 0 to 12 bar	0 Without bushing 1 1/8" port 2 1/4" port 3 3/8" port <hr/> 0 Without bushing 3 3/8" port 4 1/2" port 5 3/4" port 6 1" port

● Not available in the anti-corrosion version.
RMSA: drain with manual condensate discharge and automatic discharge at zero pressure.
RA: automatic drain with condensate discharge, independent of pressure and flow rate.

PURCHASE ORDER CODES HAVING A MORE FREQUENT USE

N.B. Besides the below mentioned codes, you can order elements composed at your will according to the key to codes.

Code	Description	Code	Description	Code	Description
FILTER-REGULATOR Syntesi® SY1		FILTER-REGULATOR Syntesi® SY1		FILTER-REGULATOR Syntesi® SY2	
5610B140	FR SY1 5 08 RMSA without bushings	5613B143	FR SY1 3/8 5 08 RMSA	5624B144	FR SY2 1/2 5 08 RMSA
5610B240	FR SY1 20 08 RMSA without bushings	5613B243	FR SY1 3/8 20 08 RMSA	5624B244	FR SY2 1/2 20 08 RMSA
5610B440	FR SY1 5 08 RA without bushings	5613B443	FR SY1 3/8 5 08 RA	5624B444	FR SY2 1/2 5 08 RA
5610B540	FR SY1 20 08 RA without bushings	5613B543	FR SY1 3/8 20 08 RA	5624B544	FR SY2 1/2 20 08 RA
5610B160	FR SY1 5 012 RMSA without bushings	5613B163	FR SY1 3/8 5 012 RMSA	5624B164	FR SY2 1/2 5 012 RMSA
5610B260	FR SY1 20 012 RMSA without bushings	5613B263	FR SY1 3/8 20 012 RMSA	5624B264	FR SY2 1/2 20 012 RMSA
5610B460	FR SY1 5 012 RA without bushings	5613B463	FR SY1 3/8 5 012 RA	5624B464	FR SY2 1/2 5 012 RA
5610B560	FR SY1 20 012 RA without bushings	5613B563	FR SY1 3/8 20 012 RA	5624B564	FR SY2 1/2 20 012 RA
FILTER-REGULATOR Syntesi® SY1		FILTER-REGULATOR Syntesi® SY2			
5611B141	FR SY1 1/8 5 08 RMSA	5620B140	FR SY2 5 08 RMSA without bushings	5625B145	FR SY2 3/4 5 08 RMSA
5611B241	FR SY1 1/8 20 08 RMSA	5620B240	FR SY2 20 08 RMSA without bushings	5625B245	FR SY2 3/4 20 08 RMSA
5611B441	FR SY1 1/8 5 08 RA	5620B440	FR SY2 5 08 RA without bushings	5625B445	FR SY2 3/4 5 08 RA
5611B541	FR SY1 1/8 20 08 RA	5620B540	FR SY2 20 08 RA without bushings	5625B545	FR SY2 3/4 20 08 RA
5611B161	FR SY1 1/8 5 012 RMSA	5620B160	FR SY2 5 012 RMSA without bushings	5625B165	FR SY2 3/4 5 012 RMSA
5611B261	FR SY1 1/8 20 012 RMSA	5620B260	FR SY2 20 012 RMSA without bushings	5625B265	FR SY2 3/4 20 012 RMSA
5611B461	FR SY1 1/8 5 012 RA	5620B460	FR SY2 5 012 RA without bushings	5625B465	FR SY2 3/4 5 012 RA
5611B561	FR SY1 1/8 20 012 RA	5620B560	FR SY2 20 012 RA without bushings	5625B565	FR SY2 3/4 20 012 RA
5612B142	FR SY1 1/4 5 08 RMSA	5623B143	FR SY2 3/8 5 08 RMSA	5626B146	FR SY2 1 5 08 RMSA
5612B242	FR SY1 1/4 20 08 RMSA	5623B243	FR SY2 3/8 20 08 RMSA	5626B246	FR SY2 1 20 08 RMSA
5612B442	FR SY1 1/4 5 08 RA	5623B443	FR SY2 3/8 5 08 RA	5626B446	FR SY2 1 5 08 RA
5612B542	FR SY1 1/4 20 08 RA	5623B543	FR SY2 3/8 20 08 RA	5626B546	FR SY2 1 20 08 RA
5612B162	FR SY1 1/4 5 012 RMSA	5623B163	FR SY2 3/8 5 012 RMSA	5626B166	FR SY2 1 5 012 RMSA
5612B262	FR SY1 1/4 20 012 RMSA	5623B263	FR SY2 3/8 20 012 RMSA	5626B266	FR SY2 1 20 012 RMSA
5612B462	FR SY1 1/4 5 012 RA	5623B463	FR SY2 3/8 5 012 RA	5626B466	FR SY2 1 5 012 RA
5612B562	FR SY1 1/4 20 012 RA	5623B563	FR SY2 3/8 20 012 RA	5626B566	FR SY2 1 20 012 RA
NOTE					
Anti-corrosion version					
5X - - - - -					
Example					
5X11B141 FR SY1 1/8 5 08 RMSA anti-corrosion					

The pneumatic lubricator is the simplest way of efficiently lubricating the actuators linked to a circuit. As compressed air flows towards the lubricator, it encounters a flexible diaphragm which partially blocks the way, creating a small pressure difference between the inlet and outlet air. Being at the higher pressure, the oil in the bowl is pumped through a tube with a filter towards the regulation pin. The quantity of oil can be metered accurately since the drops can be viewed through the transparent dome.

Filling with oil must take place in the absence of pressure, unscrewing the plug next to the dome. On the front and back there is a port (1/8" for size 1 and 1/4" for size 2) that can be used with pressure gauges, pressure switches or as an additional air intake.



TECHNICAL DATA	LUB SY1			LUB SY2						
	1/8"	1/4"	3/8"	3/8"	1/2"	3/4"	1"			
Threaded port	Oil mist									
Type of lubrication	Manual filling from the top									
Version										
Max. input pressure	bar			13						
	MPa			1.3						
	psi			188						
Flow rate at 6.3 bar (0.63 MPa; 91 psi) ΔP 0.5 bar (0.05 MPa; 7 psi)	Nl/min	1300	1700	2200	2300	3900	3900			
	scfm	46	60	78	81	138	138			
Flow rate at 6.3 bar (0.63 MPa; 91 psi) ΔP 1 bar (0.1 MPa; 14 psi)	Nl/min	1600	3000	3650	3650	6100	6100			
	scfm	57	106	129	129	216	216			
Min/max temperature at 10 bar; 1 MPa; 145 psi	°C			From -10 to +50						
Weight	g			185	180	171	480	453	449	437
Fluid	Compressed air or other inert gases									
Quantity of filled oil	cm ³			60				130		
Mounting position	Vertical			Vertical				Vertical		
Port for additional air take-off	1/8", front and rear, lubricated air			1/4", front and rear, lubricated air				1/4", front and rear, lubricated air		
Additional air take-off flow rate at 6.3 bar (0.63 MPa; 91 psi) ΔP 1 bar (0.1 MPa; 14 psi)	Nl/min	450			800					
	scfm	16			53					
Wall fixing screws	No. 2 M4 screws			No. 2 M5 screws						
Recommended oils	ISO and UNI FD22 (Energol HPL; Spinesso; Mobil DTE; Tellus oil)									
Notes on use	Install the lubricator as close as possible to the point of use. Fill the lubricator bowl with oil before pressurizing the system. Do not use cleaning oils, brake fluid oils or solvents in general. For the best lubrication results, set the drip rate to one drop for 300-600 Nl.									

COMPONENTS

- ① Technopolymer oil filling plug
- ② Technopolymer flange
- ③ IN/OUT bushing made of OT58 nickel-plated brass or passivated aluminium for 3/4" - 1"
- ④ Venturi NBR diaphragm
- ⑤ Technopolymer body
- ⑥ Clear technopolymer bowl
- ⑦ OT 58 brass oil flow regulation needle
- ⑧ Clear technopolymer cover
- ⑨ NBR o-ring gasket
- ⑩ Rilsan[®] oil suction pipe
- ⑪ Oil filter

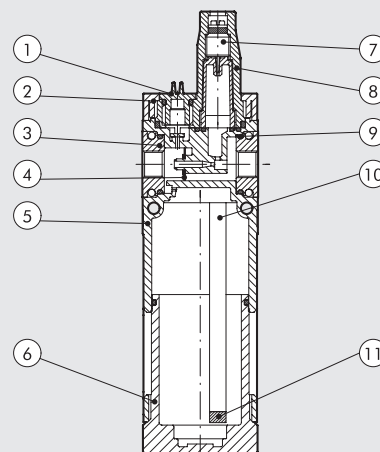

FLOW CHARTS

LUB Syntesi® SY1 1/8"

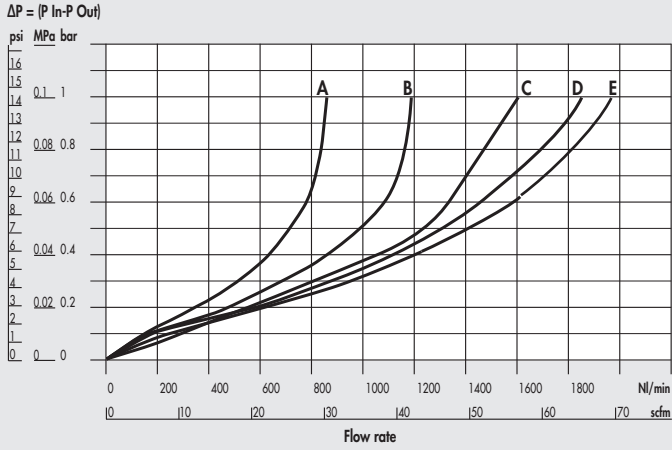

LUB Syntesi® SY1 1/4"

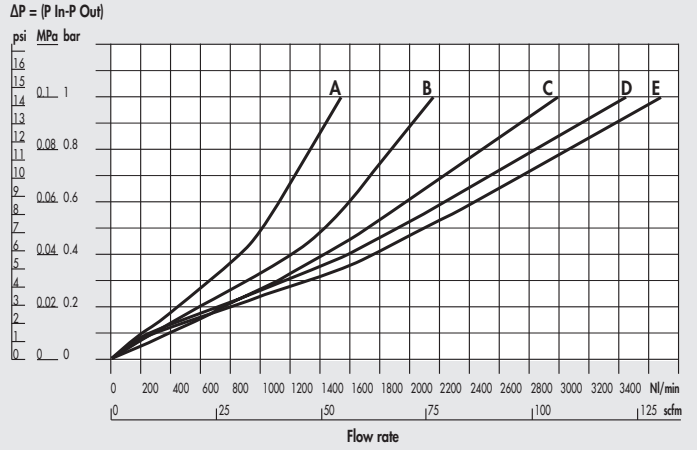

LUB Syntesi® SY1 3/8"

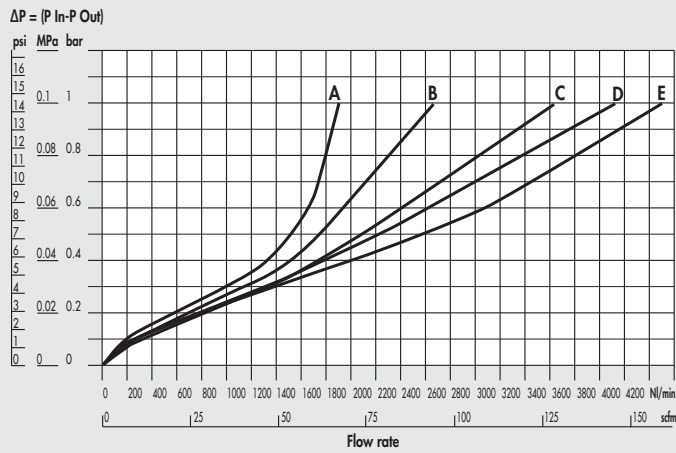

Minimum operating flow chart SY1

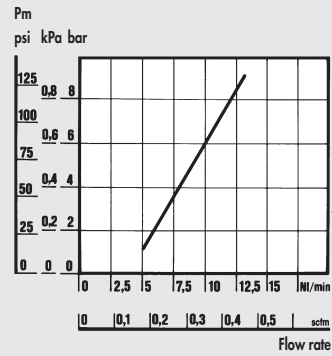

LUB Syntesi® SY2 3/8"

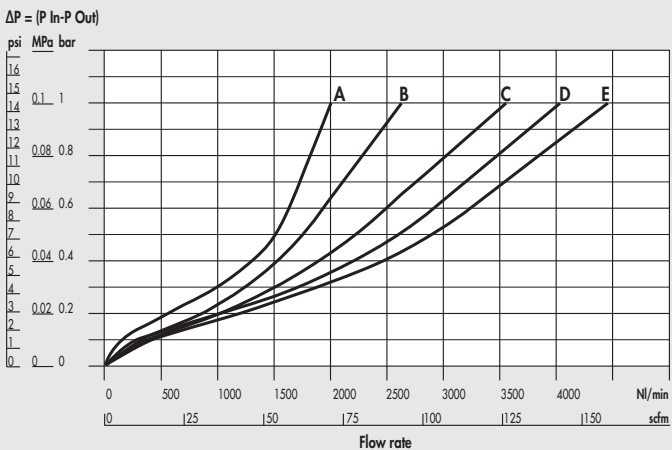

LUB Syntesi® SY2 1/2"

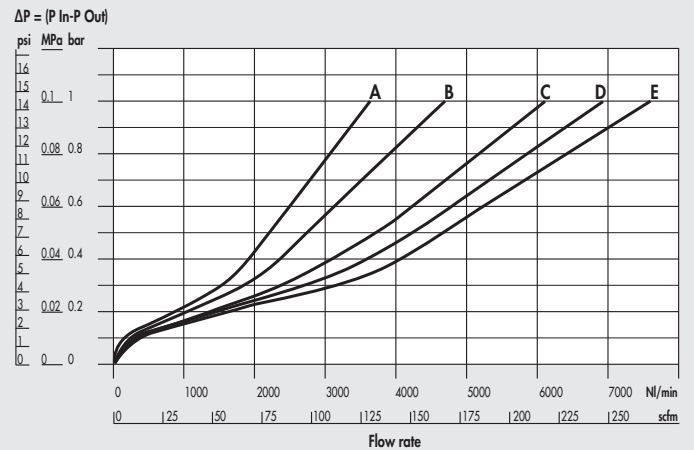

A = 2.5 bar - 0.25 MPa - 36 psi
B = 4 bar - 0.4 MPa - 58 psi

C = 6.3 bar - 0.63 MPa - 91 psi
D = 8 bar - 0.8 MPa - 116 psi

E = 10 bar - 1 MPa - 145 psi

LUB Syntesi® SY2 3/4" - 1"

$\Delta P = (P_{in} - P_{out})$

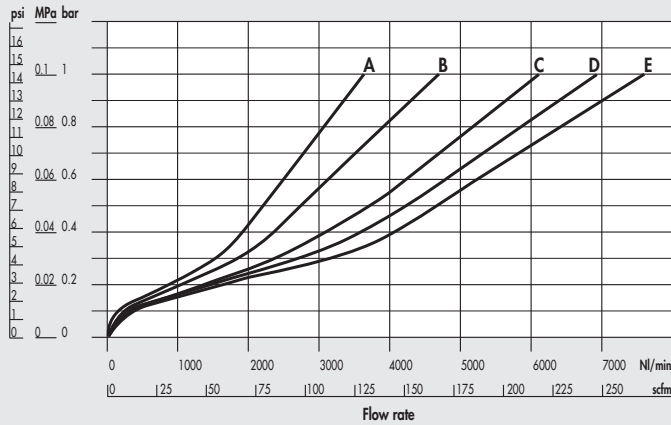

A = 2.5 bar - 0.25 MPa - 36 psi
 B = 4 bar - 0.4 MPa - 58 psi

C = 6.3 bar - 0.63 MPa - 91 psi
 D = 8 bar - 0.8 MPa - 116 psi

E = 10 bar - 1 MPa - 145 psi

Minimum operating flow chart SY2

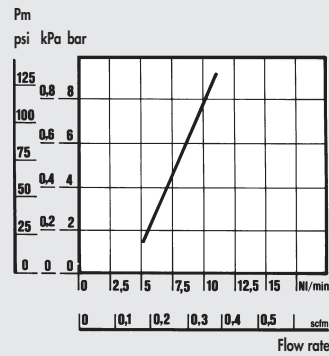

DIMENSIONS

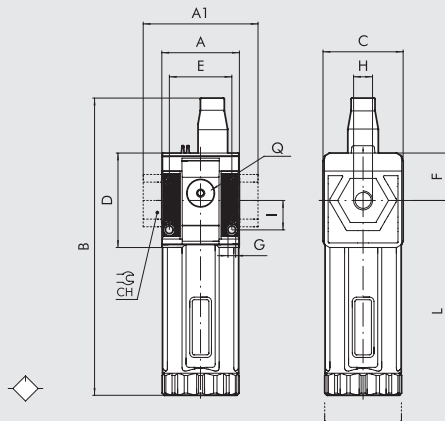

	SIZE 1			SIZE 2			
H (threaded port)	1/8"	1/4"	3/8"	3/8"	1/2"	3/4"	1"
A	42					61	
A1	-	-	44	-	-	95	95
B	162					200.5	
C	44					61	
CH	-			-	-	32	36
D	51.5					70.5	
E	33.5					47.5	
F	25.8					38.2	
G	Hole for M4 screws			Hole for M5 screws			
I	16					22.5	
L	158					193	
Q (no. 2 additional air takes-off)	1/8"					1/4"	

KEY TO CODES

56 SYNTESI	1 SIZE	1 THREADED INPUT CONNECTION	L ELEMENT	10 OIL FILLING	1 THREADED OUTPUT CONNECTION
56 Syntesi 5X Syntesi anti-corrosion	1 Size 1	0 Without bushing 1 1/8" port 2 1/4" port 3 3/8" port	L Lubricator	10 Manual filling from the top	0 Without bushing 1 1/8" port 2 1/4" port 3 3/8" port
	2 Size 2	0 Without bushing 3 3/8" port 4 1/2" port 5 3/4" port 6 1" port			0 Without bushing 3 3/8" port 4 1/2" port 5 3/4" port 6 1" port

PURCHASE ORDER CODES HAVING A MORE FREQUENT USE

N.B. Besides the below mentioned codes, you can order elements composed at your will according to the key to codes.

Code	Description	Code	Description	NOTE
Syntesi® SY1 LUBRICATOR		Syntesi® SY2 LUBRICATOR		Anti-corrosion version
5610L100	LUB SY1 without bushings	5620L100	LUB SY2 without bushings	5X_ _ _ _ _
5611L101	LUB SY1 1/8	5623L103	LUB SY2 3/8	Example
5612L102	LUB SY1 1/4	5624L104	LUB SY2 1/2	5X11L101 LUB SY1 1/8 anti-corrosion
5613L103	LUB SY1 3/8	5625L105	LUB SY2 3/4	
		5626L106	LUB SY2 1	

SYNTESI® SHUT-OFF VALVE

This device separates the compressed air circuit from the main air supply. It is a three-way valve that relieves the downstream system in the closed position. This makes it useful for maintenance operations or when the air supply to a machine or piece of equipment needs to be shut off.

Manual, pneumatic, electro-pneumatic and assisted electro-pneumatic control versions are available. The last version must be used if the inlet pressure is outside the electro-pneumatic valve operating range, so for particularly low or high pressures.

The version with manual control can be locked and you can enter up to two padlocks on size 1 and up to three on size 2 when the valve is in the closed position. On the front and back there is a port (1/8" for size 1 and 1/4" size 2) that can be used with pressure gauges, pressure switches or as an additional air intake.



TECHNICAL DATA

	V3V SY1			V3V SY2			
	1/8"	1/4"	3/8"	3/8"	1/2"	3/4"	1"
Threaded port	1/8"	1/4"	3/8"	3/8"	1/2"	3/4"	1"
Threaded discharge port	1/8"			1/4"			
Type of control	Manual - pneumatic - Elpn - Elpn pilot-assisted			Manual - Pneumatic - Cnomo elpn - Cnomo elpn pilot-assisted			
Max inlet pressure for pneumatic and solenoid pilot-assisted versions	bar 15			bar 13			
	MPa 1.5			MPa 1.3			
	psi 217			psi 188			
Inlet pressure for solenoid version	bar 3 - 10			bar 3 - 10			
	MPa 0.3 - 1			MPa 0.3 - 1			
	psi 43 - 145			psi 43 - 145			
Pilot pressure for pneumatic and solenoid pilot-assisted versions	bar 3 - 10			bar 3 - 10			
	MPa 0.3 - 1			MPa 0.3 - 1			
	psi 43 - 145			psi 43 - 145			
Flow rate at 6.3 bar (0.63 MPa; 91 psi) ΔP 0.5 bar (0.05 MPa; 7 psi)	Nl/min 800	Nl/min 1000	Nl/min 1100	Nl/min 2800	Nl/min 3000	Nl/min 3000	
	scfm 28	scfm 35	scfm 39	scfm 99	scfm 106	scfm 106	
Flow rate at 6.3 bar (0.63 MPa; 91 psi) ΔP 1 bar (0.1 MPa; 14 psi)	Nl/min 1100	Nl/min 1500	Nl/min 1600	Nl/min 3600	Nl/min 4000	Nl/min 4000	
	scfm 39	scfm 53	scfm 57	scfm 127	scfm 141.5	scfm 141.5	
Exhaust flow rate at 6.3 bar (0.63 MPa; 91 psi)	Nl/min 500			Nl/min 2000			
	scfm 18			scfm 71			
Min/max temperature at 10 bar; 1 MPa; 145 psi	°C From -10 to +50			°C From -10 to +50			
Padlockable knob				Included			
Weight	g 197	g 192	g 183	g 476	g 449	g 445	g 433
Fluid	Compressed air or other inert gases						
Mounting position	In any position						
Additional air take-off, for pressure gauges or fittings	1/8", front and rear			1/4", front and rear			
Additional air take-off flow rate at 6.3 bar (0.63 MPa; 91 psi) ΔP 1 bar (0.1 MPa; 14 psi)	Nl/min 500			Nl/min 1500			
	scfm 18			scfm 53			
Wall fixing screws	No. 2 M4 screws			No. 2 M5 screws			
Bobbin capacity for electro-pneumatic version	W 12 VDC and 24 VDC = 2W 24 VAC, 110 VAC and 220 VAC = 3.5 VA			W 24 VDC = 4W; 24 VAC, 110 VAC, 220 VAC = 4 VA			
Manual control of electro-pneumatic versions	Bistable: horizontal = OFF, vertical = ON						

COMPONENTS

- ① Technopolymer knob
- ② Technopolymer hinge
- ③ Technopolymer body
- ④ NBR o-ring gasket
- ⑤ IN/OUT bushing made of OT58 nickel-plated brass or passivated aluminium for 3/4" - 1"
- ⑥ OT58 brass valve with NBR vulcanized gasket
- ⑦ Stainless steel valve spring
- ⑧ Technopolymer plug
- ⑨ OT58 brass threaded insert
- ⑩ Galvanised steel plate for knob locking (stainless steel for anti-corrosion version)
- ⑪ Stainless steel spring stem recovery
- ⑫ OT58 brass stem

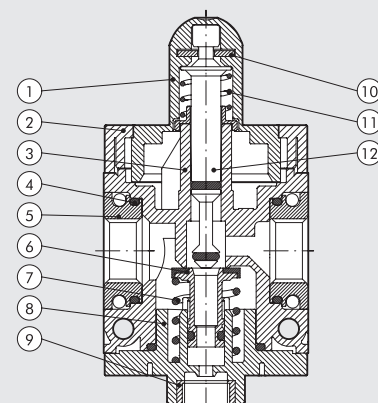

DIMENSIONS

MANUAL

SY1-SY2

PNEUMATIC

SY1-SY2

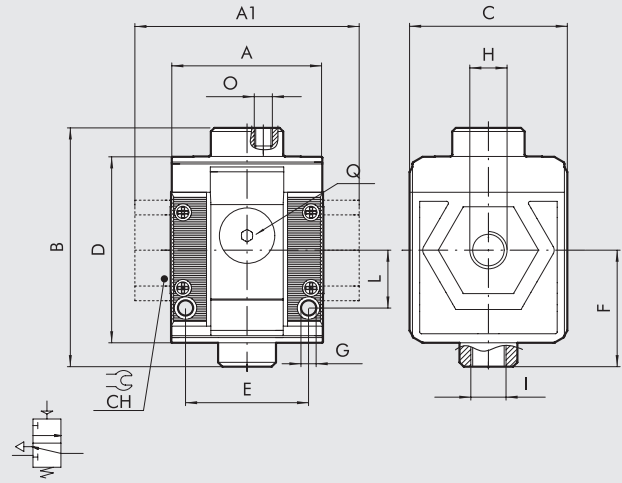
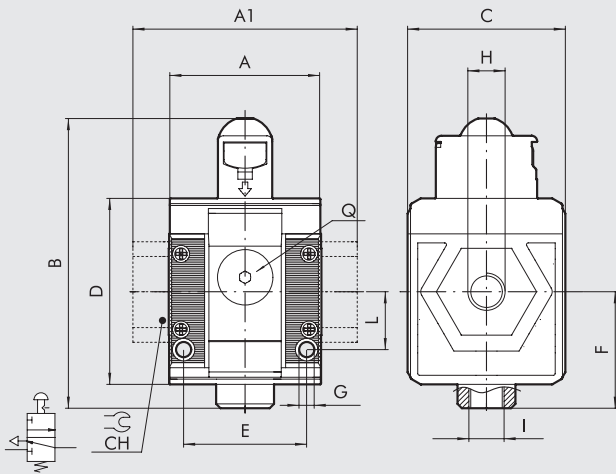

SOLENOID/SOLENOID PILOT-ASSISTED*

SY1

CNOMO SOLENOID / CNOMO SOLENOID PILOT-ASSISTED*

SY2

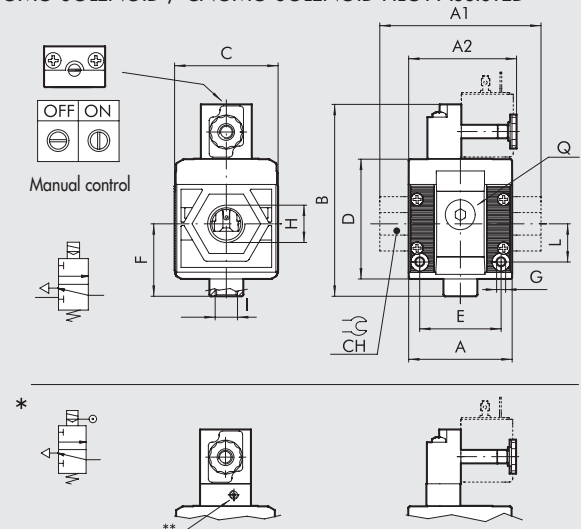
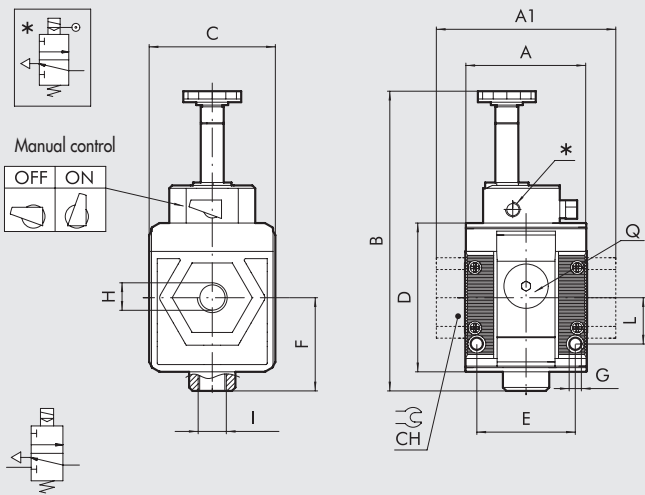

	MANUAL						PNEUMATIC						SOLENOID/SOLENOID PILOT-ASSISTED			CNOMO SOLENOID/CNOMO SOLENOID PILOT-ASSISTED					
	SIZE 1			SIZE 2			SIZE 1			SIZE 2			SIZE 1			SIZE 2					
H (threaded port)	1/8"	1/4"	3/8"	3/8"	1/2"	3/4"	1"	1/8"	1/4"	3/8"	3/8"	1/2"	3/4"	1"	1/8"	1/4"	3/8"	3/8"	1/2"	3/4"	1"
A	-	42	-	-	61	-	-	-	42	-	-	61	-	-	-	42	-	-	61	-	-
A1	-	-	44	-	-	95	95	-	-	44	-	-	95	95	-	-	44	-	-	95	95
A2	-	-	-	-	-	-	-	-	-	-	-	-	-	-	-	-	-	-	-	65	-
B	80	-	-	109	-	-	-	66	-	-	94	-	-	-	104	-	-	-	-	-	113
Cnomo	-	-	-	-	-	-	-	-	-	-	-	-	-	-	-	-	-	-	-	-	126
Cnomo pilot ass.	-	-	-	-	-	-	-	-	-	-	-	-	-	-	-	-	-	-	-	-	61
C	44	-	-	61	-	-	-	44	-	-	61	-	-	-	44	-	-	-	-	-	61
CH	-	-	-	-	32	36	-	-	-	-	32	36	-	-	-	-	-	-	-	32	36
D	51.5	-	-	70.5	-	-	-	51.5	-	-	70.5	-	-	-	51.5	-	-	-	-	-	70.5
E	33.5	-	-	47.5	-	-	-	33.5	-	-	47.5	-	-	-	33.5	-	-	-	-	-	47.5
F	32.2	-	-	42.7	-	-	-	32.2	-	-	42.7	-	-	-	32.2	-	-	-	-	-	42.7
G	Hole for M4 screws			Hole for M5 screws			-	Hole for M4 screws			Hole for M5 screws			Hole for M4 screws			Hole for M5 screws				
I (exhaust)	1/8"	-	-	1/4"	-	-	-	1/8"	-	-	1/8"	-	-	-	1/8"	-	-	-	-	-	1/4"
L	16	-	-	22.5	-	-	-	16	-	-	22.5	-	-	-	16	-	-	-	-	-	22.5
O (pilot)	-	-	-	-	-	-	-	M5	-	-	1/8"	-	-	-	-	-	-	-	-	-	-
Q (no. 2 additional air takes-off)	1/8"	-	-	1/4"	-	-	-	1/8"	-	-	1/4"	-	-	-	1/8"	-	-	-	-	-	1/4"
** Pilot	-	-	-	-	-	-	-	-	-	-	-	-	-	-	M5	-	-	-	-	-	M5

KEY TO CODES

56	1	1	V	10	1
SYNTESI	SIZE	THREADED INPUT CONNECTION	ELEMENT	TYPE	THREADED OUTPUT CONNECTION
56 Syntesi 5X Syntesi anti-corrosion	1 Size 1 <hr/> 2 Size 2	0 Without bushing 1 1/8" port 2 1/4" port 3 3/8" port <hr/> 0 Without bushing 3 3/8" port 4 1/2" port 5 3/4" port 6 1" port	V Shut-off valve	10 Manual ● 20 Pneumatic ● 30 Solenoid pilot-assisted ● 70 Solenoid	0 Without bushing 1 1/8" port 2 1/4" port 3 3/8" port <hr/> 0 Without bushing 3 3/8" port 4 1/2" port 5 3/4" port 6 1" port

● Not available in the anti-corrosion version.

PURCHASE ORDER CODES HAVING A MORE FREQUENT USE

N.B. Besides the below mentioned codes, you can order elements composed at your will according to the key to codes.

Code	Description	Code	Description	NOTE
Syntesi® SY1 SHUT-OFF VALVE		Syntesi® SY2 SHUT-OFF VALVE		Anti-corrosion version 5X ----- Example 5X11V101 V3V SY1 1/8 anti-corrosion
5610V100	V3V SY1 manual without bushings	5620V100	V3V SY2 manual without bushings	
5611V101	V3V SY1 1/8 manual	5623V103	V3V SY2 3/8 manual	
5612V102	V3V SY1 1/4 manual	5624V104	V3V SY2 1/2 manual	
5613V103	V3V SY1 3/8 manual	5625V105	V3V SY2 3/4 manual	
5610V200	V3V SY1 pneumatic without bushings	5626V106	V3V SY2 1 manual	
5611V201	V3V SY1 1/8 pneumatic	5620V200	V3V SY2 pneumatic without bushings	
5612V202	V3V SY1 1/4 pneumatic	5623V203	V3V SY2 3/8 pneumatic	
5613V203	V3V SY1 3/8 pneumatic	5624V204	V3V SY2 1/2 pneumatic	
5610V300	V3V SY1 elpn pilot-assisted without bushings	5625V205	V3V SY2 3/4 pneumatic	
5611V301	V3V SY1 1/8 elpn pilot-assisted	5626V206	V3V SY2 1 pneumatic	
5612V302	V3V SY1 1/4 elpn pilot-assisted	5620V300	V3V SY2 elpn pilot-assisted Cnomo without bushings	
5613V303	V3V SY1 3/8 elpn pilot-assisted	5623V303	V3V SY2 3/8 elpn pilot-assisted Cnomo	
5610V700	V3V SY1 elpn without bushings	5624V304	V3V SY2 1/2 elpn pilot-assisted Cnomo	
5611V701	V3V SY1 1/8 elpn	5625V305	V3V SY2 3/4 elpn pilot-assisted Cnomo	
5612V702	V3V SY1 1/4 elpn	5626V306	V3V SY2 1 elpn pilot-assisted Cnomo	
5613V703	V3V SY1 3/8 elpn	5620V700	V3V SY2 elpn without bushings	
		5623V703	V3V SY2 3/8 elpn	
		5624V704	V3V SY2 1/2 elpn	
		5625V705	V3V SY2 3/4 elpn	
		5626V706	V3V SY2 1 elpn	

NOTES

The progressive starter is a pneumatic component that allows air enter the circuit gradually, thereby avoiding excessive pressure bursts.

A sophisticated system of internal valves allows two separate stages of operation. During the first stage, a quantity of air that can be regulated via a pin flows from the APR. The second stage starts when the downstream pressure reached 40 to 60% of the upstream pressure, during which full-port flow is achieved. When the mechanism is deactivated, the air flow is cut off and the downstream circuit is relieved.

The progressive starter is particularly useful on machinery where it is important to prevent actuators from moving rapidly and out of control, or where, for safety reasons, the air in-feed needs to be gentle and gradual. It, however, there is a major leak in the downstream system, it may never be possible to achieve the pressure required to open the valve completely.

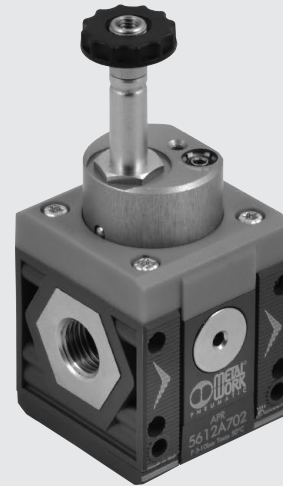

TECHNICAL DATA	APR SY1			APR SY2			
	1/8"	1/4"	3/8"	3/8"	1/2"	3/4"	1"
Threaded port		1/8"	3/8"	3/8"	1/2"	3/4"	1"
Threaded discharge port		1/8"			1/4"		
Type of control		Solenoid		Solenoid - Cnomo solenoid			
Inlet pressure	bar	3 - 10		3 - 10			
	MPa	0.3 - 1		0.3 - 1			
	psi	43 - 145		43 - 145			
Flow rate at 6.3 bar (0.63 MPa; 91 psi) ΔP 0.5 bar (0.05 MPa; 7 psi)	Nl/min	900	1000	1100	2800	3600	3600
	scfm	32	39	39	99	127	127
Flow rate at 6.3 bar (0.63 MPa; 91 psi) ΔP 1 bar (0.1 MPa; 14 psi)	Nl/min	1250	1500	1600	4400	4800	4800
	scfm	44	53	57	156	170	170
Drain flow rate at 6.3 bar (0.63 MPa; 91 psi)	Nl/min	500			2700		
	scfm	18			96		
Maximum flow rate start-up, at 6.3 bar (0.63 MPa; 91 psi) with regulation pin completely unscrewed	Nl/min	170			700		
	scfm	6			25		
Min/max temperature at 10 bar; 1 MPa; 145 psi	°C	From -10 to +50			From -10 to +50		
Weight	g	203	198	189	503	476	472
Fluid		Compressed air or other inert gases					
Mounting position		In any position					
Additional air take-off, for pressure gauges or fittings		1/8", front and rear			1/4", front and rear		
Additional air take-off flow rate at 6.3 bar (0.63 MPa; 91 psi) ΔP 1 bar (0.1 MPa; 14 psi)	Nl/min	500			1500		
	scfm	18			53		
Wall fixing screws		No. 2 M4 screws			No. 2 M5 screws		
Bobbin capacity for electro-pneumatic version	W	12 VDC and 24 VDC = 2W; 24 VAC, 110 VAC and 220 VAC = 3.5 VA for Cnomo versions: 24 VDC = 4W; 24 VAC, 110 VAC, 220 VAC = 4 VA					
Manual control		Bistable: horizontal = OFF, vertical = ON					

COMPONENTS

- ① Sleeve ø8
- ② Anodized aluminium upper block
- ③ Technopolymer flange
- ④ Technopolymer body
- ⑤ IN/OUT bushing made of OT58 nickel-plated brass or passivated aluminium for 3/4" - 1"
- ⑥ O-ring NBR gasket
- ⑦ Stainless steel valve spring
- ⑧ Technopolymer bottom plug
- ⑨ OT58 brass progressive start regulation pin
- ⑩ OT58 brass internal valve
- ⑪ Stainless steel spring stem recoveryng
- ⑫ OT58 brass stem
- ⑬ OT58 brass main valve with vulcanized gasket
- ⑭ OT58 brass threaded insert

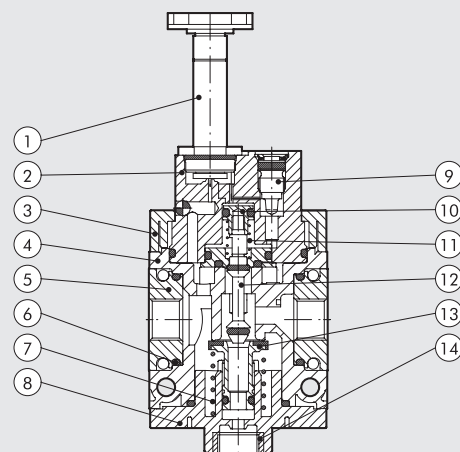

DIMENSIONS

SOLENOID

SY1-SY2

CNOMO SOLENOID

SY2

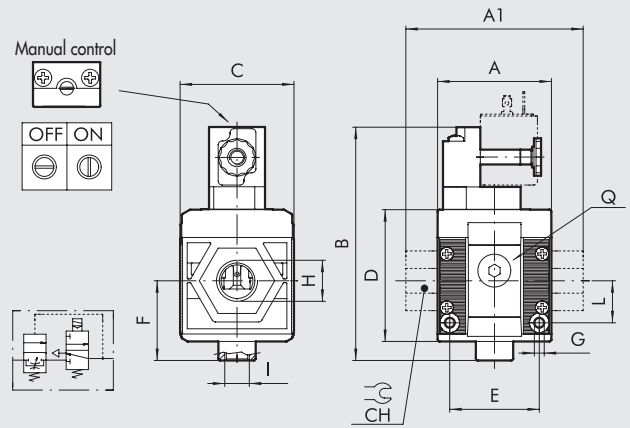
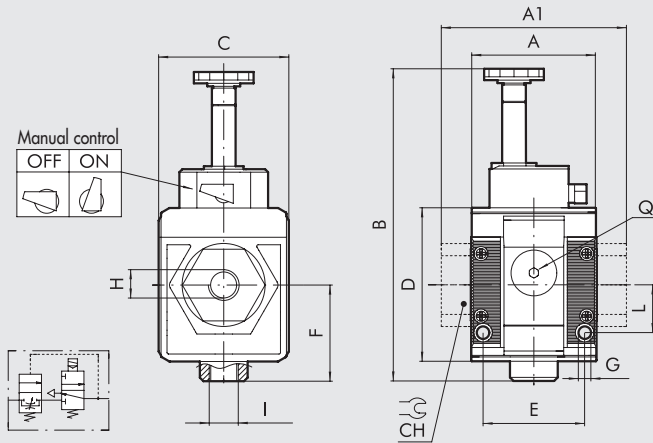

	SOLENOID SIZE 1			SOLENOID / CNOMO SOLENOID SIZE 2			
	H (threaded port)	1/8"	1/4"	3/8"	3/8"	1/2"	3/4"
A		42				61	
A1	-	-	44	-	-	95	95
B		105				131	
C		-				125	
	Cnomo					61	
CH		-		-	-	32	36
D		51.5				70.5	
E		33.5				47.5	
F		32.2				42.7	
G		Hole for M4 screws				Hole for M5 screws	
I (exhaust)		1/8"				1/4"	
L		16				22.5	
Q (no. 2 additional air takes-off)		1/8"				1/4"	

KEY TO CODES

56	1	1	A	70	1
SYNTESI	SIZE	THREADED INPUT CONNECTION	ELEMENT	TYPE	THREADED OUTPUT CONNECTION
56 Syntesi	1 Size 1	0 Without bushing 1 1/8" port 2 1/4" port 3 3/8" port	A Progressive starter APR	70 Solenoid * 71 Cnomo solenoid	0 Without bushing 1 1/8" port 2 1/4" port 3 3/8" port
	2 Size 2	0 Without bushing 3 3/8" port 4 1/2" port 5 3/4" port 6 1" port			0 Without bushing 3 3/8" port 4 1/2" port 5 3/4" port 6 1" port

* Only for size 2

PURCHASE ORDER CODES HAVING A MORE FREQUENT USE

N.B. Besides the below mentioned codes, you can order elements composed at your will according to the key to codes.

Code	Description	Code	Description	Code	Description
Syntesi® SY1 PROGRESSIVE STARTER		Syntesi® SY2 PROGRESSIVE STARTER		Syntesi® SY2 PROGRESSIVE STARTER	
5610A700	APR SY1 elpn without bushings	5620A700	APR SY2 elpn without bushings	5620A710	APR SY2 elpn Cnomo without bushings
5611A701	APR SY1 1/8 elpn	5623A703	APR SY2 3/8 elpn	5623A713	APR SY2 3/8 elpn Cnomo
5612A702	APR SY1 1/4 elpn	5624A704	APR SY2 1/2 elpn	5624A714	APR SY2 1/2 elpn Cnomo
5613A703	APR SY1 3/8 elpn	5625A705	APR SY2 3/4 elpn	5625A715	APR SY2 3/4 elpn Cnomo
		5626A706	APR SY2 1 elpn	5626A716	APR SY2 1 elpn Cnomo

Syntesi® pressure switches feature a high degree of miniaturisation and a modern attractive design. As they are extremely modular, the Syntesi® series can be installed facing up or down. They come ready assembled with a 2-metre cable or an M8 connector with a 300-mm cable. The contact is the switching type, which means it can be normally open or normally closed. It can be regulated via a knurled push-lock handle. On the front and back there is a port (1/8" for size 1 and 1/4" size 2) that can be used with pressure gauges or as an additional air intake.



TECHNICAL DATA	SY1 PRESSURE SWITCHES			SY2 PRESSURE SWITCHES			
	1/8"	1/4"	3/8"	3/8"	1/2"	3/4"	1"
Threaded port							
Adjustable pressure interval	bar 0.5 ÷ 10			bar 0.5 ÷ 10			
Hysteresis (not adjustable)	bar From 0.4 to 0.8 (See diagram)						
Maximum pressure	bar 15			bar 13			
	MPa 1.5			MPa 1.3			
	psi 217			psi 188			
Min/Max temperature at 10 bar; 1 MPa; 145 psi	°C From -10 to 50			°C From -10 to 50			
Maximum current	A 2			A 2			
Maximum voltage	V 250			V 250			
Outside diameter of cable	mm 4.9			mm 4.9			
Number of wires and cross section	3 x 0.5 mm ²			3 x 0.5 mm ²			
Contacts	Normally-Open (NO) and Normally-Closed (NC)						
Protection	IP65			IP65			
Number of switchings	5 x 10 ⁶			5 x 10 ⁶			
Fluid	Filtered lubricated or unlubricated compressed air. Lubrication, if used, must be continuous						
Mounting position	In any position						
Additional air take-off, for pressure gauges or fittings	1/8", front and rear			1/4", front and rear			
Additional air take-off flow rate at 6.3 bar (0.63 MPa; 91 psi) ΔP 1 bar (0.1 MPa; 14 psi)	NL/min 500			NL/min 1500			
	scfm 18			scfm 53			
Wall fixing screws	No. 2 M4 screws			No. 2 M5 screws			
Weight	g 255	g 250	g 241	g 443	g 416	g 412	g 400

COMPONENTS

- ① Technopolymer adjusting "push lock" handle
- ② OT58 brass adjusting screw
- ③ Steel piston spring
- ④ OT58 brass piston
- ⑤ Aluminium top plug
- ⑥ Technopolymer body
- ⑦ IN/OUT bushing made of OT58 nickel-plated brass or passivated aluminium for 3/4" - 1"
- ⑧ Technopolymer bottom plug
- ⑨ Technopolymer pressure switch body
- ⑩ Resin finish for IP65
- ⑪ Electrical contact
- ⑫ O-ring NBR gasket
- ⑬ Technopolymer flange

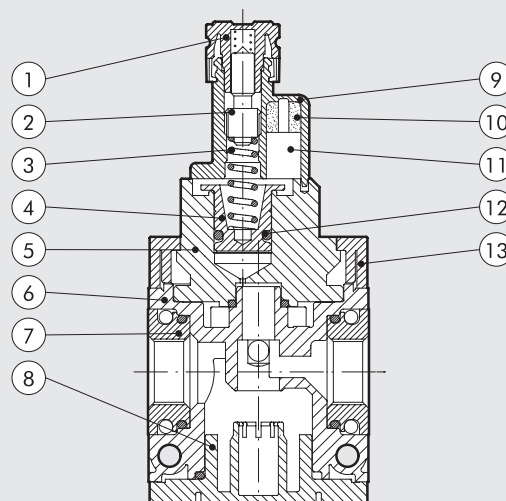

DIMENSIONS

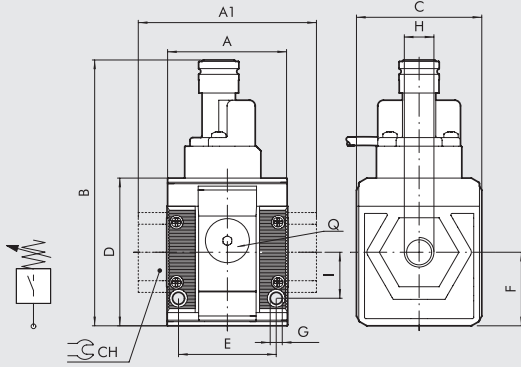

	SIZE 1			SIZE 2			
H (threaded port)	1/8"	1/4"	3/8"	3/8"	1/2"	3/4"	1"
A	42			61			
A1	-	-	44	-	-	95	95
B	93			101			
C	44			61			
CH	-			-	-	32	36
D	51.5			70.5			
E	33.5			47.5			
F	25.6			32.5			
G	Hole for M4 screws			Hole for M5 screws			
I	16			22.5			
Q (no. 2 additional air takes-off)	1/8"			1/4"			

HYSTERESIS GRAPH

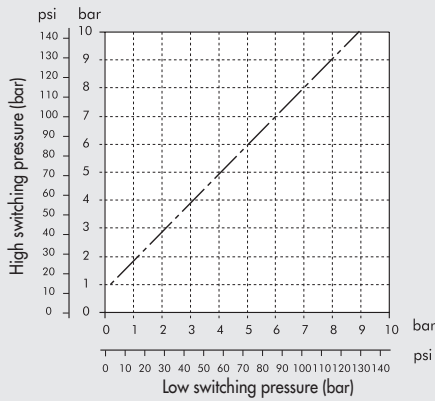

WIRING DIAGRAM

VERSION WITH CABLE

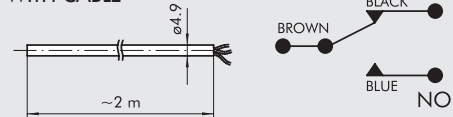

VERSION WITH M8 CONNECTOR

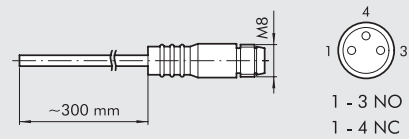

KEY TO CODES

56	1	1	S	10	1
SYNTESI	SIZE	THREADED INPUT CONNECTION	ELEMENT	TYPE	THREADED OUTPUT CONNECTION
56 Syntesi	1 Size 1	0 Without bushing 1 1/8" port 2 1/4" port 3 3/8" port	S Pressure switches	10 2 m cable 20 300 mm cable with M8 connector	0 Without bushing 1 1/8" port 2 1/4" port 3 3/8" port
	2 Size 2	3 3/8" port 4 1/2" port 5 3/4" port 6 1" port			0 Without bushing 3 3/8" port 4 1/2" port 5 3/4" port 6 1" port

PURCHASE ORDER CODES HAVING A MORE FREQUENT USE

N.B. Besides the below mentioned codes, you can order elements composed at your will according to the key to codes.

Code	Descrizione	Code	Description
Syntesi® SY1 PRESSURE SWITCHES		Syntesi® SY2 PRESSURE SWITCHES	
5610S100	Pressure switch 2 m cable SY1 without bushings	5620S100	Pressure switch 2 m cable SY2 without bushings
5611S101	Pressure switch 2 m cable SY1 1/8	5623S103	Pressure switch 2 m cable SY2 3/8
5612S102	Pressure switch 2 m cable SY1 1/4	5624S104	Pressure switch 2 m cable SY2 1/2
5613S103	Pressure switch 2 m cable SY1 3/8	5625S105	Pressure switch 2 m cable SY2 3/4
		5626S106	Pressure switch 2 m cable SY2 1
5610S200	Pressure switch M8 SY1 connector without bushings	5620S200	Pressure switch M8 SY2 connector without bushings
5611S201	Pressure switch M8 connector SY1 1/8	5623S203	Pressure switch M8 connector SY2 3/8
5612S202	Pressure switch M8 connector SY1 1/4	5624S204	Pressure switch M8 connector SY2 1/2
5613S203	Pressure switch M8 connector SY1 3/8	5625S205	Pressure switch M8 connector SY2 3/4
		5626S206	Pressure switch M8 connector SY2 1

ACCESSOIRES: SECURITY KNOB

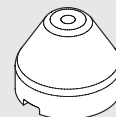

Code	Description
9200703	Security knob

NOTE: Pull outwards to remove the knob from the pressure switch on the unit. Insert the security knob and regulate the pressure switch. Then press the handle firmly to lock it in position. If the pressure switch needs to be reset, remove the security knob by forcing it laterally with a screwdriver.

The air take-off is a connecting element that is mounted between two Syntesi® modules. The 2-way version, made of metal and having restrained dimensions, has a threaded port upwards and one downwards. The 4-way version, in technopolymer, has a threaded port on each side. This gives or four additional air outlets for use as required. All Syntesi® modules come with two threaded ports, one on the front and one on the back, for use as air take-off.



TECHNICAL DATA	AIR TAKE-OFF		AIR TAKE-OFF, 4-WAY	
	SIZE 1	SIZE 2	SIZE 1	SIZE 2
Flow rate of the air take-off at 6.3 bar (0.63 MPa; 91 psi) ΔP 1 bar (0.1 MPa; 14 psi)	Nl/min	1550	7000	500 - 2000
	scfm	55	248	18 - 71
Usage temperature and pressure	Given by the Syntesi® modules it's connected to			
Weight	g	62	75	100
Fluid	Compressed air or other inert gases			

DIMENSIONS 2 WAY-VERSION

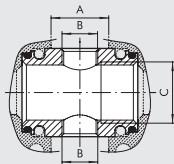

	SIZE 1	SIZE 2
A	15.5	27
B	1/8"	3/8"
C	3/8"	1/2"

DIMENSIONS 4 WAY-VERSION

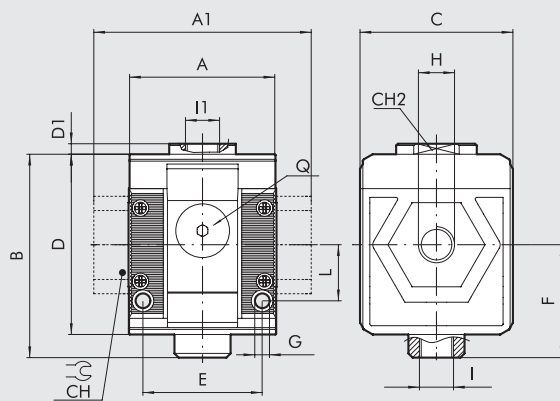

	SIZE 1			SIZE 2			
H (threaded port)	1/8"	1/4"	3/8"	3/8"	1/2"	3/4"	1"
A	42			61			
A1	-	-	44	-	-	95	95
B	58			81			
C	44			61			
CH	-			-	-	32	36
CH2	19			-			
D	51.5			70.5			
D1	3			-			
E	33.5			47.5			
F	32.2			42.7			
G	Hole for M4 screws			Hole for M5 screws			
I	1/8"			1/4"			
I1	1/4"			3/8"			
L	16			22.5			
Q (no. 2 add. air takes-off)	1/8"			1/4"			

KEY TO CODE FOR 4-WAY VERSION

56	1	1	P	20	1
SYNTESI	SIZE	THREADED INPUT CONNECTION	ELEMENT	TYPE	THREADED OUTPUT CONNECTION
56 Syntesi	1 Size 1	0 Without bushing	P Air take-off	20 4-way	0 Without bushing
5X Syntesi anti-corrosion		1 1/8" port			1 1/8" port
		2 1/4" port			2 1/4" port
		3 3/8" port			3 3/8" port
	2 Size 2	0 Without bushing			0 Without bushing
		3 3/8" port			3 3/8" port
		4 1/2" port	4 1/2" port		
		5 3/4" port	5 3/4" port		
		6 1" port	6 1" port		

PURCHASE ORDER CODES HAVING A MORE FREQUENT USE CODES

Code	Description
AIR INTAKE, 2-way version	
5610P100	PA SY1
5620P100	PA SY2
AIR INTAKE, 4-way version	
5610P200	PA 4-way SY1 without bushing
5611P201	PA 4-way SY1 1/8
5612P202	PA 4-way SY1 1/4
5613P203	PA 4-way SY1 3/8
5620P200	PA 4-way SY2 without bushing
5623P203	PA 4-way SY2 3/8
5624P204	PA 4-way SY2 1/2
5625P205	PA 4-way SY2 3/4
5626P206	PA 4-way SY2 1
NOTE	
Anti-corrosion version	
5X _____	
Example	
5X11P201	PA 4-way SY1 1/8 anti-corrosion

N.B. Besides the below mentioned codes, you can order elements composed at your will according to the key to codes.

For full details and list of components refer to the sections about filter-regulator and the lubricator.



TECHNICAL DATA	FR + LUB SY1			FR + LUB SY2			
	1/8"	1/4"	3/8"	3/8"	1/2"	3/4"	1"
Threaded port							
Degree of filtration	5 (yellow) - output air purity class ISO8573-1: 3.7- 20 (white) - output air purity class ISO8573-1: 4.7- 50 (blue) - output air purity class ISO8573-1: 5.7-						
Max. inlet pressure	15 bar 1.5 MPa 217 psi			13 bar 1.3 MPa 188 psi			
Flow rate at 6.3 bar (0.63 MPa; 91 psi) ΔP 0.5 bar (0.05 MPa; 7 psi)	NL/min scfm			NL/min scfm			
Flow rate at 6.3 bar (0.63 MPa; 91 psi) ΔP 1 bar (0.1 MPa; 14 psi)	NL/min scfm			NL/min scfm			
Relief valve flow rate at 6.3 bar (0.63 MPa; 91 psi)	NL/min scfm			NL/min scfm			
Min/max temperature at 10 bar; 1 MPa; 145 psi	From -10 to +50			From -10 to +50			
Padlockable knob	Included						
Upstream pressure compensation	Included, via balanced valve						
Weight	414	409	400	1074	1047	1043	1031
Fluid	Compressed air or other inert gases						
Mounting position	Vertical			Vertical			
Additional air take-off, for pressure gauges or fittings	1/8", front and rear			1/4", front and rear			
Additional air take-off flow rate at 6.3 bar (0.63 MPa; 91 psi) ΔP 1 bar (0.1 MPa; 14 psi)	NL/min scfm			NL/min scfm			
Filter bowl capacity (condensate)	cm ³			cm ³			
Quantity of filled oil	cm ³			cm ³			
Condensate drain	RMSA: drain with manual condensate discharge and automatic discharge at zero pressure RA: automatic drain with condensate discharge, independent of pressure and flow rate Note: the maximum input pressure for the RA version must not exceed 10 bar						
Recommended oils	ISO and UNI FD22 (Energol HPL; Spinesso; Mobil DTE; Tellus oil)						
Wall fixing screws	No. 2 M4 screws			No. 2 M5 screws			

DIMENSIONS

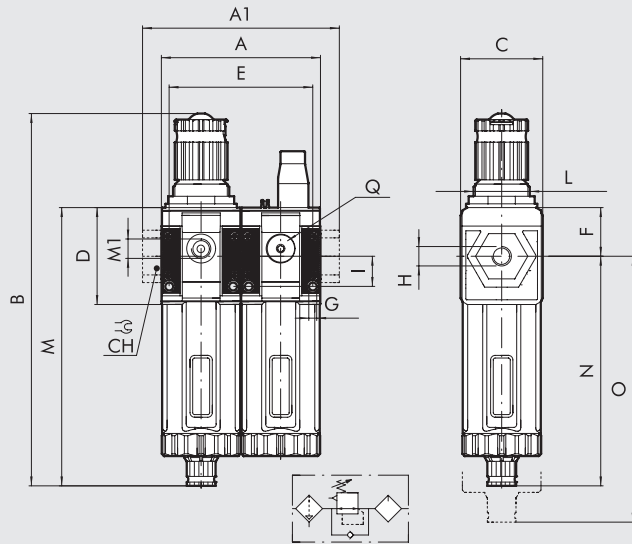

	SIZE 1			SIZE 2			
	1/8"	1/4"	3/8"	3/8"	1/2"	3/4"	1"
H (threaded port)	1/8"	1/4"	3/8"	3/8"	1/2"	3/4"	1"
A	84			122			
A1	-	-	86	-	-	156	156
B	RMSA RA			246 250			
C	44			61			
CH	-			32 36			
D	51.5			70.5			
E	75.3			108			
F	25.8			38.2			
G	Hole for M4 screws			Hole for M5 screws			
I	16			22.5			
L	M30x1.5			M38x2			
M	RMSA RA			178 182			
M1 (pressure gauge port)	1/8"			1/4"			
N	RMSA RA			139.8 143.8			
O	RMSA RA			245 249			
Q (no. 2 additional air takes-off)	1/8"			1/4"			

KEY TO CODES

56	1	1	B	24	L	10	1
SYNTESI	SIZE	THREADED INPUT CONNECTION	ELEMENT	DEGREE OF FILTRATION, TYPE OF CONDENSATE DRAIN AND SETTING RANGE	ELEMENT	OIL FILLING	THREADED OUTPUT CONNECTION
56 Syntesi 5X Syntesi anti-corrosion	1 Size 1 2 Size 2	1 1/8" port 2 1/4" port 3 3/8" port 4 1/2" port 5 3/4" port 6 1" port	B Filter-regulator	<ul style="list-style-type: none"> ● 10 5 μm, RMSA, 0 to 2 bar ● 20 20 μm, RMSA, 0 to 2 bar ● 30 50 μm, RMSA, 0 to 2 bar ● 40 5 μm, RA, 0 to 2 bar ● 50 20 μm, RA, 0 to 2 bar ● 60 50 μm, RA, 0 to 2 bar ● 12 5 μm, RMSA, 0 to 4 bar ● 22 20 μm, RMSA, 0 to 4 bar ● 32 50 μm, RMSA, 0 to 4 bar ● 42 5 μm, RA, 0 to 4 bar ● 52 20 μm, RA, 0 to 4 bar ● 62 50 μm, RA, 0 to 4 bar 14 5 μm, RMSA, 0 to 8 bar 24 20 μm, RMSA, 0 to 8 bar 34 50 μm, RMSA, 0 to 8 bar 44 5 μm, RA, 0 to 8 bar 54 20 μm, RA, 0 to 8 bar 64 50 μm, RA, 0 to 8 bar 16 5 μm, RMSA, 0 to 12 bar 26 20 μm, RMSA, 0 to 12 bar 36 50 μm, RMSA, 0 to 12 bar 46 5 μm, RA, 0 to 12 bar 56 20 μm, RA, 0 to 12 bar 66 50 μm, RA, 0 to 12 bar 	L Lubricator	10 Manual filling from the top	1 1/8" port 2 1/4" port 3 3/8" port 4 1/2" port 5 3/4" port 6 1" port

● Not available in the anti-corrosion version.

RMSA: drain with manual condensate discharge and automatic discharge at zero pressure.
RA: automatic drain with condensate discharge, independent of pressure and flow rate.

PURCHASE ORDER CODES HAVING A MORE FREQUENT USE

N.B. Besides the below mentioned codes, you can order elements composed at your will according to the key to codes.

Code	Description	Code	Description	NOTE
FR + LUB Syntesi® SY1		FR + LUB Syntesi® SY2		Anti-corrosion version
5611B24L101	FR+LUB SY1 1/8 20 08 RMSA	5623B24L103	FR+LUB SY2 3/8 20 08 RMSA	5X
5611B54L101	FR+LUB SY1 1/8 20 08 RA	5623B54L103	FR+LUB SY2 3/8 20 08 RA	Example
5612B24L102	FR+LUB SY1 1/4 20 08 RMSA	5624B24L104	FR+LUB SY2 1/2 20 08 RMSA	5X11B54L101
5612B54L102	FR+LUB SY1 1/4 20 08 RA	5624B54L104	FR+LUB SY2 1/2 20 08 RA	FR+LUB SY1 1/8 20 08 RA anti-corrosion
5613B24L103	FR+LUB SY1 3/8 20 08 RMSA	5625B24L105	FR+LUB SY2 3/4 20 08 RMSA	
5613B54L103	FR+LUB SY1 3/8 20 08 RA	5625B54L105	FR+LUB SY2 3/4 20 08 RA	
		5626B24L106	FR+LUB SY2 1 20 08 RMSA	
		5626B54L106	FR+LUB SY2 1 20 08 RA	

V3V + FR + LUB SYNTESI®

For full details and list of components refer to the sections about shut-off valve, filter-regulator and lubricator.



UNITS

V3V + FR + LUB Syntesi®

TECHNICAL DATA	V3V + FR + LUB SY1			V3V + FR + LUB SY2			
	1/8"	1/4"	3/8"	3/8"	1/2"	3/4"	1"
Threaded port	1/8"	1/4"	3/8"	3/8"	1/2"	3/4"	1"
Degree of filtration	5 (yellow) - output air purity class ISO8573-1: 3.7.- 20 (white) - output air purity class ISO8573-1: 4.7.- 50 (blue) - output air purity class ISO8573-1: 5.7.-						
Max. inlet pressure	15 bar			13 bar			
	1.5 MPa			1.3 MPa			
	217 psi			188 psi			
Flow rate at 6.3 bar (0.63 MPa; 91 psi) ΔP 0.5 bar (0.05 MPa; 7 psi)	250 Nl/min			1200 Nl/min			
(P In=10 bar)	9 scfm			42.5 scfm			
Flow rate at 6.3 bar (0.63 MPa; 91 psi) ΔP 1 bar (0.1 MPa; 14 psi)	1050 Nl/min			4000 Nl/min			
(P In=10 bar)	37 scfm			141.5 scfm			
Relief valve flow rate at 6.3 bar (0.63 MPa; 91 psi)	70 Nl/min			100 Nl/min			
	2.5 scfm			3.5 scfm			
Min/max temperature at 10 bar; 1 MPa; 145 psi	From -10 to +50 °C			From -10 to +50 °C			
Full outflow with zero inlet pressure	Included			Included			
Drain flow rate at 6.3 bar (0.63 MPa; 91 psi)	500 Nl/min			2000 Nl/min			
	18 scfm			71 scfm			
Padlockable knob	Included with both V3V and regulator						
Upstream pressure compensation	Included, via balanced valve						
Weight	598 g	593 g	584 g	1479 g	1452 g	1448 g	1436 g
Fluid	Compressed air or other inert gases						
Mounting position	Vertical			Vertical			
Additional air take-off, for pressure gauges or fittings	1/8", front and rear			1/4", front and rear			
Additional air take-off flow rate at 6.3 bar (0.63 MPa; 91 psi) ΔP 1 bar (0.1 MPa; 14 psi)	500 (V3V) - 500 (FR) - 450 (LUB) Nl/min			1500 (V3V) - 1400 (FR) - 800 (LUB) Nl/min			
	18 (V3V) - 18 (FR) - 16 (LUB) scfm			53 (V3V) - 49.5 (FR) - 28 (LUB) scfm			
Filter bowl capacity	30 cm ³			70 cm ³			
Quantity of filled oil	60 cm ³			130 cm ³			
Condensate drain	RMSA: drain with manual condensate discharge and automatic discharge at zero pressure RA: automatic drain with condensate discharge, independent of pressure and flow rate Note: the maximum input pressure for the RA version must not exceed 10 bar						
Recommended oils	ISO and UNI FD22 (Energol HPL; Spinesso; Mobil DTE; Tellus oil)						
Wall fixing screws	No. 2 M4 screws			No. 2 M5 screws			

OVERALL DIMENSIONS

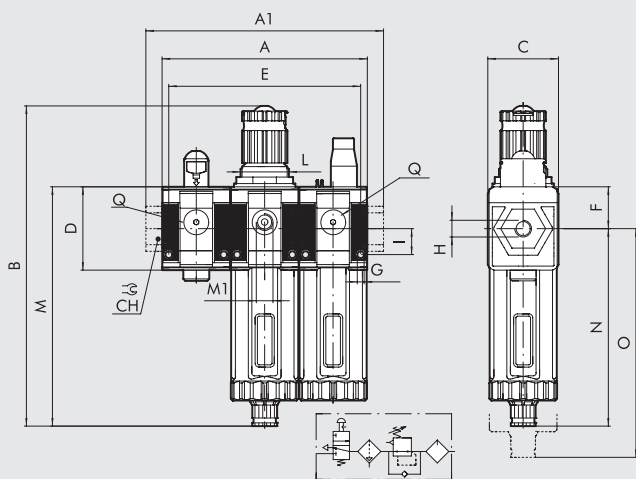

	SIZE 1			SIZE 2			
	1/8"	1/4"	3/8"	3/8"	1/2"	3/4"	1"
H (threaded port)	1/8"	1/4"	3/8"	3/8"	1/2"	3/4"	1"
A	-	126	-	-	-	183	-
A1	-	-	128	-	-	217	217
B	RMSA			246			
	RA			250			
C	44			61			
CH	-			32	36		
D	51.5			70.5			
E	117.1			168.5			
F	25.8			38.2			
G	Hole for M4 screws			Hole for M5 screws			
I	16			22.5			
L	M30x1.5			M38x2			
M	RMSA			178			
	RA			182			
M1 (pressure gauge port)	1/8"			1/4"			
N	RMSA			139.8			
	RA			143.8			
O	RMSA			245			
	RA			249			
Q (no. 2 additional air takes-off)	1/8"			1/4"			

KEY TO CODES

56	1	1	V	10	B	24	L	10	1
SYNTESI	SIZE	THREADED INPUT CONNECTION	ELEMENT	TYPE	ELEMENT	DEGREE OF FILTRATION, TYPE OF CONDENSATE DRAIN AND SETTING RANGE	ELEMENT	OIL FILLING	THREADED OUTPUT CONNECTION
56 Syntesi	1 Size 1	1 1/8" port	V V3V	10 Manual	B Filter-regulator	● 10 5 μm, RMSA, 0 to 2 bar	L Lubricator	10 Manual filling from the top	1 1/8" port
5X Syntesi anti-corrosion	2 Size 2	2 1/4" port				● 20 20 μm, RMSA, 0 to 2 bar			2 1/4" port
		3 3/8" port				● 30 50 μm, RMSA, 0 to 2 bar			3 3/8" port
		4 1/2" port				● 40 5 μm, RA, 0 to 2 bar			4 1/2" port
		5 3/4" port				● 50 20 μm, RA, 0 to 2 bar			5 3/4" port
		6 1" port				● 60 50 μm, RA, 0 to 2 bar			6 1" port
						● 12 5 μm, RMSA, 0 to 4 bar			
						● 22 20 μm, RMSA, 0 to 4 bar			
						● 32 50 μm, RMSA, 0 to 4 bar			
						● 42 5 μm, RA, 0 to 4 bar			
						● 52 20 μm, RA, 0 to 4 bar			
						● 62 50 μm, RA, 0 to 4 bar			
						14 5 μm, RMSA, 0 to 8 bar			
						24 20 μm, RMSA, 0 to 8 bar			
						34 50 μm, RMSA, 0 to 8 bar			
						44 5 μm, RA, 0 to 8 bar			
						54 20 μm, RA, 0 to 8 bar			
						64 50 μm, RA, 0 to 8 bar			
						16 5 μm, RMSA, 0 to 12 bar			
						26 20 μm, RMSA, 0 to 12 bar			
						36 50 μm, RMSA, 0 to 12 bar			
						46 5 μm, RA, 0 to 12 bar			
						56 20 μm, RA, 0 to 12 bar			
						66 50 μm, RA, 0 to 12 bar			

● Not available in the anti-corrosion version.

RMSA: drain with manual condensate discharge and automatic discharge at zero pressure.
RA: automatic drain with condensate discharge, independent of pressure and flow rate.

PURCHASE ORDER CODES HAVING A MORE FREQUENT USE

N.B. Besides the below mentioned codes, you can order elements composed at your will according to the key to codes.

Code	Description	Code	Description	NOTE
V3V + FR + LUB Syntesi [®] SY1		V3V + FR + LUB Syntesi [®] SY2		Anti-corrosion version
5611V10B24L101	V3V+FR+LUB SY1 1/8 20 08 RMSA	5623V10B24L103	V3V+FR+LUB SY2 3/8 20 08 RMSA	5X-----
5611V10B54L101	V3V+FR+LUB SY1 1/8 20 08 RA	5623V10B54L103	V3V+FR+LUB SY2 3/8 20 08 RA	Example
5612V10B24L102	V3V+FR+LUB SY1 1/4 20 08 RMSA	5624V10B24L104	V3V+FR+LUB SY2 1/2 20 08 RMSA	5X11V10B54L101
5612V10B54L102	V3V+FR+LUB SY1 1/4 20 08 RA	5624V10B54L104	V3V+FR+LUB SY2 1/2 20 08 RA	V3V+FR+LUB SY1 1/8 20 08 RA
5613V10B24L103	V3V+FR+LUB SY1 3/8 20 08 RMSA	5625V10B24L105	V3V+FR+LUB SY2 3/4 20 08 RMSA	anti-corrosion
5613V10B54L103	V3V+FR+LUB SY1 3/8 20 08 RA	5625V10B54L105	V3V+FR+LUB SY2 3/4 20 08 RA	
		5626V10B24L106	V3V+FR+LUB SY2 1 20 08 RMSA	
		5626V10B54L106	V3V+FR+LUB SY2 1 20 08 RA	

FIL + DEP SYNTESI®

For full details and list of components refer to the sections about filter and depurator.



UNITS

FIL + DEP Syntesi®

TECHNICAL DATA	FIL + DEP SY1			FIL + DEP SY2			
	1/8"	1/4"	3/8"	3/8"	1/2"	3/4"	1"
Threaded port	1/8" 1/4" 3/8" 3/8" 1/2" 3/4" 1"						
Purifier degree of filtration	0.01 - output air purity class ISO8573-1: 1.7.2						
Filter degree of filtration	5 (yellow)						
Max. inlet pressure	15			13			
	1.5			1.3			
	217			188			
Suggested flow rate at 6.3 bar (0.63 MPa; 91 psi)	550			1050			
	9			37			
Maximum suggested flow rate	Look at the chart on the depurator page 3-12			Look at the chart on the depurator page 3-12 / 3-13			
	NB: flow rates higher than the recommended value reduces purification efficiency						
Min/max temperature at 10 bar; 1 MPa; 145 psi	From -10 to +50			From -10 to +50			
Weight	358	353	344	942	915	911	899
Purifier condensate drain	RMSA: drain with manual condensate discharge and automatic discharge at zero pressure						
Filter condensate drain	RMSA: drain with manual condensate discharge and automatic discharge at zero pressure RA: automatic drain with condensate discharge, independent of pressure and flow rate						
	Note: the maximum input pressure for the RA version must not exceed 10 bar						
Fluid	Compressed air or other inert gases						
Bowl capacity filter/depurator	30/15			70/40			
Mounting position	Vertical			Vertical			
Port for additional air take-off	1/8", front and rear			1/4", front and rear			
Additional air take-off flow rate (not purified air)	500			1500			
at 6.3 bar (0.63 MPa; 91 psi) ΔP 1 bar (0.1 MPa; 14 psi)	18			53			
Wall fixing screws	No. 2 M4 screws			No. 2 M5 screws			

DIMENSIONS

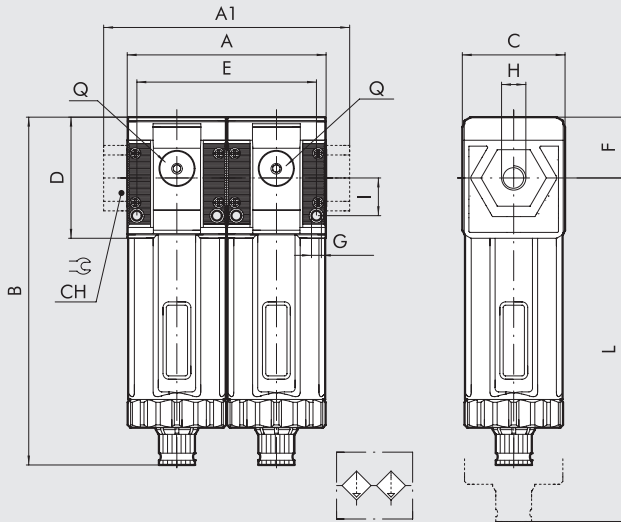

	SIZE 1			SIZE 2			
	1/8"	1/4"	3/8"	3/8"	1/2"	3/4"	1"
H (threaded port)	1/8"	1/4"	3/8"	3/8"	1/2"	3/4"	1"
A	84			122			
A1	-	-	86	-	-	217	217
B	RMSA RA			178 182			
C	44			61			
CH	-			32 36			
D	51.5			70.5			
E	75.3			108			
F	25.8			38.2			
G	Hole for M4 screws			Hole for M5 screws			
I	16			22.5			
L	RMSA RA			245 249			
Q (no. 2 additional air takes-off)	1/8"			1/4"			

KEY TO CODES

56	1	1	F	10	D	10	1
SYNTESI	SIZE	THREADED INPUT CONNECTION	ELEMENT	DEGREE OF FILTRATION AND TYPE OF CONDENSATE DRAIN	ELEMENT	TYPE	THREADED OUTPUT CONNECTION
56 Syntesi 5X Syntesi anti-corrosion	1 Size 1 2 Size 2	1 1/8" port 2 1/4" port 3 3/8" port 3 3/8" port 4 1/2" port 5 3/4" port 6 1" port	F Filter	10 5 µm, RMSA 40 5 µm, RA	D Depurator	10 RMSA	1 1/8" port 2 1/4" port 3 3/8" port 3 3/8" port 4 1/2" port 5 3/4" port 6 1" port

RMSA: drain with manual condensate discharge and automatic discharge at zero pressure.
RA: automatic drain with condensate discharge, independent of pressure and flow rate.

PURCHASE ORDER CODES HAVING A MORE FREQUENT USE

N.B. Besides the below mentioned codes, you can order elements composed at your will according to the key to codes.

Code	Description	Code	Description	NOTE
FIL + DEP Syntesi® SY1		FIL + DEP Syntesi® SY2		Anti-corrosion version
5611F10D101	FIL+DEP SY1 1/8 05 RMSA	5623F10D103	FIL+DEP SY2 3/8 05 RMSA	5X _____
5611F40D101	FIL+DEP SY1 1/8 05 RA	5623F40D103	FIL+DEP SY2 3/8 05 RA	Example
5612F10D102	FIL+DEP SY1 1/4 05 RMSA	5624F10D104	FIL+DEP SY2 1/2 05 RMSA	5X11F40D101 FIL+DEP SY1 1/8 05 RA anti-corrosion
5612F40D102	FIL+DEP SY1 1/4 05 RA	5624F40D104	FIL+DEP SY2 1/2 05 RA	
5613F10D103	FIL+DEP SY1 3/8 05 RMSA	5625F10D105	FIL+DEP SY2 3/4 05 RMSA	
5613F40D103	FIL+DEP SY1 3/8 05 RA	5625F40D105	FIL+DEP SY2 3/4 05 RA	
		5626F10D106	FIL+DEP SY2 1 05 RMSA	
		5626F40D106	FIL+DEP SY2 1 05 RA	

For full details and list of components refer to the sections about filter and lubricator.



TECHNICAL DATA	FIL + LUB SY1			FIL + LUB SY2			
	1/8"	1/4"	3/8"	3/8"	1/2"	3/4"	1"
Threaded port							
Degree of filtration	5 (yellow) - output air purity class ISO8573-1: 3.7- 20 (white) - output air purity class ISO8573-1: 4.7- 50 (blue) - output air purity class ISO8573-1: 5.7-						
Max. inlet pressure	bar			13			
	MPa			1.3			
	psi			188			
Flow rate at 6.3 bar (0.63 MPa; 91 psi) ΔP 0.5 bar (0.05 MPa; 7 psi)	NI/min			2900			
	scfm			102.5			
Flow rate at 6.3 bar (0.63 MPa; 91 psi) ΔP 1 bar (0.1 MPa; 14 psi)	NI/min			4400			
	scfm			156			
Min/max temperature at 10 bar; 1 MPa; 145 psi	°C			From -10 to +50			
Weight	349	344	355	840	813	809	797
Fluid	Compressed air or other inert gases						
Mounting position	Vertical			Vertical			
Additional air take-off, for pressure gauges or fittings	1/8", front and rear			1/4", front and rear			
Additional air take-off flow rate at 6.3 bar (0.63 MPa; 91 psi) ΔP 1 bar (0.1 MPa; 14 psi)	NI/min			1500 - 800			
	scfm			53 - 28			
Filter bowl capacity (condensate)	cm ³			70			
Quantity of filled oil	cm ³			130			
Condensate drain	RMSA: drain with manual condensate discharge and automatic discharge at zero pressure RA: automatic drain with condensate discharge, independent of pressure and flow rate Note: the maximum input pressure for the RA version must not exceed 10 bar ISO and UNI FD22 (Energol HPL; Spinesso; Mobil DTE; Tellus oil)						
Recommended oils							
Wall fixing screws	No. 2 M4 screws			No. 2 M5 screws			

DIMENSIONS

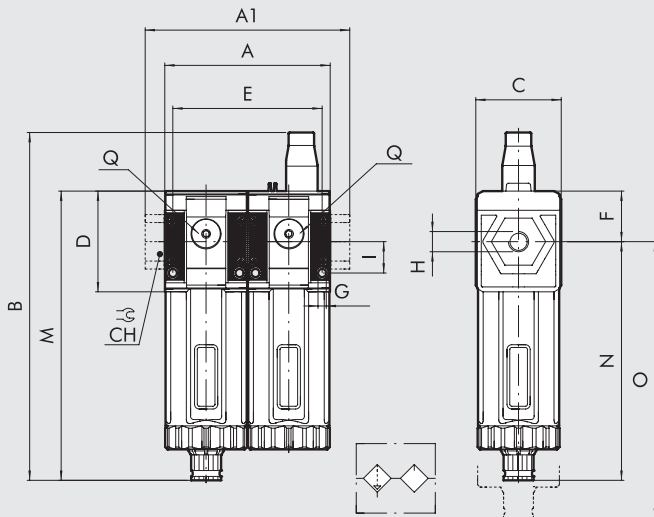

	SIZE 1			SIZE 2			
	1/8"	1/4"	3/8"	3/8"	1/2"	3/4"	1"
H (threaded port)	1/8"	1/4"	3/8"	3/8"	1/2"	3/4"	1"
A	84			122			
A1	-	-	86	-	-	156	156
B	RMSA 117.5 RA 121.5			208 212			
C	44			61			
CH	-			-	-	32	36
D	51.5			70.5			
E	75.3			108			
F	25.8			38.2			
G	Hole for M4 screws			Hole for M5 screws			
I	16			22.5			
M	RMSA 148 RA 152			178 182			
N	RMSA 122.2 RA 126.2			139.8 143.8			
O	RMSA 202 RA 206			245 249			
Q (no. 2 additional air takes-off)	1/8"			1/4"			

KEY TO CODES

56	1	1	F	10	L	10	1
SYNTESI	SIZE	THREADED INPUT CONNECTION	ELEMENT	DEGREE OF FILTRATION AND TYPE OF CONDENSATE DRAIN	ELEMENT	OIL FILLING	THREADED OUTPUT CONNECTION
56 Syntesi 5X Syntesi anti-corrosion	1 Size 1 2 Size 2	1 1/8" port 2 1/4" port 3 3/8" port 3 3/8" port 4 1/2" port 5 3/4" port 6 1" port	F Filter	10 5 µm, RMSA 20 20 µm, RMSA 30 50 µm, RMSA 40 5 µm, RA 50 20 µm, RA 60 50 µm, RA	L Lubricator	10 Manual filling from the top	1 1/8" port 2 1/4" port 3 3/8" port 3 3/8" port 4 1/2" port 5 3/4" port 6 1" port

RMSA: drain with manual condensate discharge and automatic discharge at zero pressure.
RA: automatic drain with condensate discharge, independent of pressure and flow rate.

PURCHASE ORDER CODES HAVING A MORE FREQUENT USE

N.B. Besides the below mentioned codes, you can order elements composed at your will according to the key to codes.

Code	Description	Code	Description	NOTE
FIL + LUB Syntesi® SY1				Anti-corrosion version 5X ----- Example 5X11F50L101 FIL+LUB SY1 1/8 20 RA anti-corrosion
5611F20L101	FIL+LUB SY1 1/8 20 RMSA	5623F20L103	FIL+LUB SY2 3/8 20 RMSA	
5611F50L101	FIL+LUB SY1 1/8 20 RA	5623F50L103	FIL+LUB SY2 3/8 20 RA	
5612F20L102	FIL+LUB SY1 1/4 20 RMSA	5624F20L104	FIL+LUB SY2 1/2 20 RMSA	
5612F50L102	FIL+LUB SY1 1/4 20 RA	5624F50L104	FIL+LUB SY2 1/2 20 RA	
5613F20L103	FIL+LUB SY1 3/8 20 RMSA	5625F20L105	FIL+LUB SY2 3/4 20 RMSA	
5613F50L103	FIL+LUB SY1 3/8 20 RA	5625F50L105	FIL+LUB SY2 3/4 20 RA	
		5626F20L106	FIL+LUB SY2 1 20 RMSA	
		5626F50L106	FIL+LUB SY2 1 20 RA	

SYNTESI[®] ACCESSORIES

MOUNTING BRACKET FOR REG. AND FR

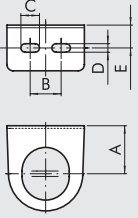

Code	Description
9200701	SF100- BIT-ND 1/4 - SY1
9400701	SF200-ND-3/8 1/2 - SY2

Code	A	B	C	D	E
9200701	32	20	12	5.5	14.2
9400701	42	40	12	5.5	15

PRESSURE GAUGES

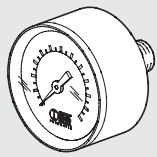

Code	Description
9700101	M 40 1/8 012
9700102	M 40 1/8 04
9800101	M 50 1/8 012
9800102	M 50 1/8 04
9900101	M 63 1/4 04

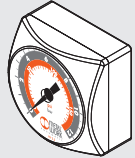

9700109	M 40x40 1/8 04
9700110	M 40x40 1/8 012

ADAPTERS FOR PRESSURE GAUGES (SY2)

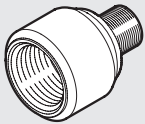

Code	Description
9210005	1/4 adapter for 1/8 pressure gauge

COIL 22 mm FOR APR AND V3V ELPN

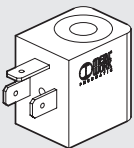

Code	Description
W0215000151	Coil 22 Ø 8 BA 2W-12VDC
W0215000101	Coil 22 Ø 8 BA 2W-24VDC
W0215000111	Coil 22 Ø 8 BA 3.5VA-24VAC
W0215000121	Coil 22 Ø 8 BA 3.5VA-110VAC
W0215000131	Coil 22 Ø 8 BA 3.5VA-220VAC

"UL" AND "CSA" COILS 22 mm

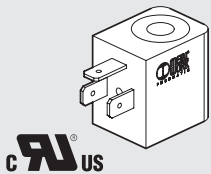

Code	Description
W0215000251	Coil 22 Ø 8 BA 2W-12VDC UR
W0215000201	Coil 22 Ø 8 BA 2W-24VDC UR
W0215000211	Coil 22 Ø 8 BA 3.5VA-24VAC UR
W0215000221	Coil 22 Ø 8 BA 3.5VA-110VAC UR
W0215000231	Coil 22 Ø 8 BA 3.5VA-220VAC UR

For the standards description look at page 6-29

COIL 30 mm FOR APR AND V3V ELPN

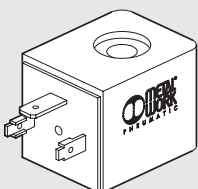

Code	Description
W0210010100	Coil 30 Ø 8 4W-24VDC
W0210011100	Coil 30 Ø 8 4VA-24VAC 50/60 HZ
W0210012100	Coil 30 Ø 8 4VA-110VAC 50/60 HZ
W0210013100	Coil 30 Ø 8 4VA-220VAC 50/60 HZ

KIT FOR COIL EEXM

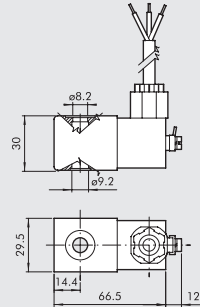

Code	Description
0227606913	Kit for coil 30 24 VDC EEXMT5 cable 3m
0227606915	Kit for coil 30 24 VDC EEXMT5 cable 5m
0227608013	Kit for coil 30 24 VAC EEXMT5 cable 3m
0227608015	Kit for coil 30 24 VAC EEXMT5 cable 5m
0227608023	Kit for coil 30 110 VAC EEXMT5 cable 3m
0227608025	Kit for coil 30 110 VAC EEXMT5 cable 5m
0227608033	Kit for coil 30 230 VAC EEXMT5 cable 3m
0227608035	Kit for coil 30 230 VAC EEXMT5 cable 5m

According to ATEX 94/9 CE rule,
 ⓧ II 2G Ex mb IIC T4/T5 Gb
 ⓧ II 2D Ex tb IIIC T130/T95 °C IP66 Db

ELECTRIC CONNECTOR 22 mm FOR APR AND V3V ELPN

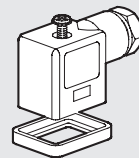

Code	Description
W0970510011	Connector standard
W0970510012	Connector 22 LED 24V
W0970510013	Connector 22 LED 110V
W0970510014	Connector 22 LED 220V
W0970510015	Connector 22 LED VDR 24V
W0970510016	Connector 22 LED VDR 110V
W0970510017	Connector 22 LED VDR 220V
W0970510070	Connector 22 II 3 GD ATEX

ELECTRIC CONNECTOR 30 mm FOR APR AND V3V ELPN

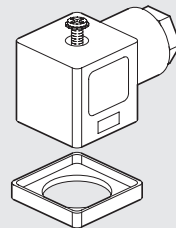

Code	Description
W0970520033	Connector 30 STD
W0970520034	Connector 30 LED 24V
W0970520035	Connector 30 LED 110V
W0970520036	Connector 30 LED 220V
W0970520037	Connector 30 LED VDR 24V
W0970520038	Connector 30 LED VDR 110V
W0970520039	Connector 30 LED VDR 220V

KIT COIL SIDE 22 IP65



Code	Description
0222100100	Kit for coils 22 - IP65

Improved IP65 protection, even after prolonged exposure to atmospheric agents.

BOWL DISASSEMBLY SPANNER

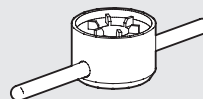

Code	Description
9170601	CS TF - TL BIT/SY1
9210050	CS TF - TL SY2

CONNECTING NIPPLE KIT

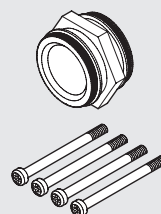

Code	Description
9210000	Connecting nipple kit SY1
9210010	Connecting nipple kit SY2
9210000X	Connecting nipple kit SY1 anti-corrosion
9210010X	Connecting nipple kit SY2 anti-corrosion

Max torque 0.4 Nm for SY1
 Max torque 2.5 Nm for SY2

THREADED PORT

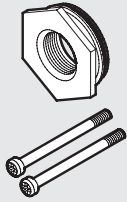

Code	Description
9210001	Kit IN OUT 1/8 SY1
9210002	Kit IN OUT 1/4 SY1
9210003	Kit IN OUT 3/8 SY1
9210011	Kit IN OUT 3/8 SY2
9210012	Kit IN OUT 1/2 SY2
9210013	Kit IN OUT 3/4 SY2
9210014	Kit IN OUT 1 SY2
9210001X	Kit IN OUT 1/8 SY1 anti-corrosion
9210002X	Kit IN OUT 1/4 SY1 anti-corrosion
9210003X	Kit IN OUT 3/8 SY1 anti-corrosion
9210011X	Kit IN OUT 3/8 SY2 anti-corrosion
9210012X	Kit IN OUT 1/2 SY2 anti-corrosion
9210013X	Kit IN OUT 3/4 SY2 anti-corrosion
9210014X	Kit IN OUT 1 SY2 anti-corrosion
Max torque 0.4 Nm for SY1	
Max torque 2.5 Nm for SY2	

WALL-FIXING SCREW



Code	Description
9210030	M4 x 55 fixing screw SY1
9210031	M5 x 75 fixing screw SY2
Max torque 0.8 Nm for SY1	
Max torque 2.0 Nm for SY2	

PADLOCK

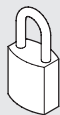

Code	Description
9062401	Padlock

KIT CONNECTING REGTRONIC 1/4 (PAGE 3-212) AND GS REGULATOR (PAGE 3-206)

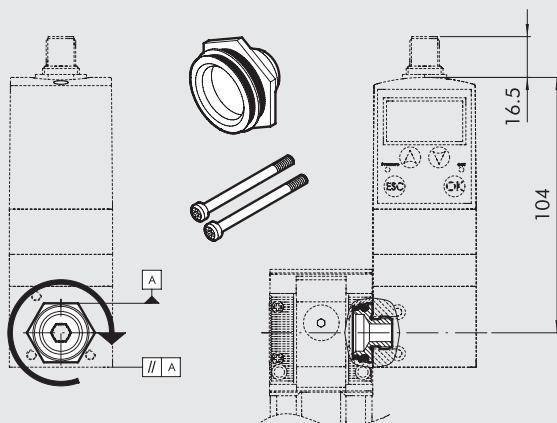

Code	Description
9210004	Adaptor for REGTRONIC 1/4 SY1

Max torque for screw, 0.4 Nm

Instructions:

- 1) Screw the connecting bushing onto the REGTRONIC 1/4 as far as it will go. Use sealant on the G1/4 thread to provide a further seal.
- 2) Unscrew the bushing slightly until two surfaces of the hexagon are parallel to the body of REGTRONIC 1/4 (see diagram).
- 3) Insert the bushing into the Syntesi® unit.
- 4) Tighten the two self-tapping screws in the Syntesi® unit to a torque of 0.4 Nm max.

SY1 - SY2 SIZE ADAPTER

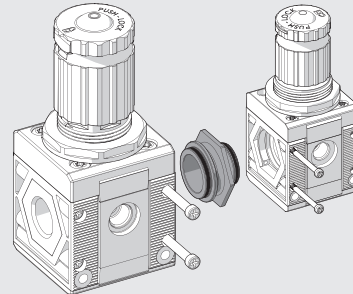

Code	Description
9210006	SY1 - SY2 size adapter
9210006X	SY1 - SY2 size adapter anti-corrosion

Max torque for screw, 0.4 Nm for SY1
Max torque for screw, 2.5 Nm for SY2

SYNTESI® SPARE PARTS

AUTOMATIC DRAIN (RA)

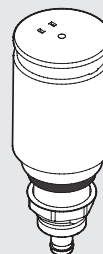

Code	Description
9000802	RA automatic drain spare part

BOWL RMSA/RA

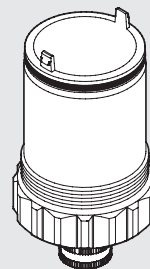

Code	Description
9210100	Bowl FIL FR DEP RMSA SY1
9210101	Bowl FIL FR RA SY1
9210105	Bowl FIL FR DEP RMSA SY2
9210106	Bowl FIL FR RA SY2

LUBRICATOR BOWL

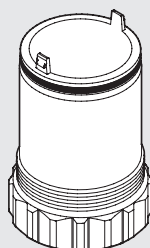

Code	Description
9210110	Bowl LUB SY1
9210115	Bowl LUB SY2

FILTERING ELEMENT

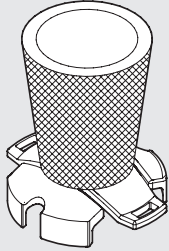

Code	Description
9210150	Filtering element 5µm (yellow) SY1
9210151	Filtering element 20µm (white) SY1
9210152	Filtering element 50µm (blue) SY1
9210155	Filtering element 5µm (yellow) SY2
9210156	Filtering element 20µm (white) SY2
9210157	Filtering element 50µm (blue) SY2

SPRINGS FOR REGULATORS AND FR

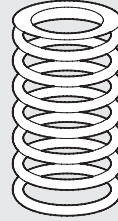

Code	Description
9210190	Spares MO 02 SY1
9210191	Spares MO 04 SY1
9210192	Spares MO 08 SY1
9210193	Spares MO 012 SY1
9210195	Spares MO 02 SY2
9210196	Spares MO 04 SY2
9210197	Spares MO 08 SY2
9210198	Spares MO 012 SY2
9210192X	Spares 08 SY1 anti-corrosion
9210193X	Spares 012 SY1 anti-corrosion
9210197X	Spares 08 SY2 anti-corrosion
9210198X	Spares 012 SY2 anti-corrosion

PURIFIER FILTERING ELEMENT

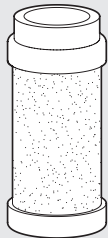

Code	Description
9210160	Cartridge DEP SY1
9210165	Cartridge DEP SY2

BELL FOR REG AND FR

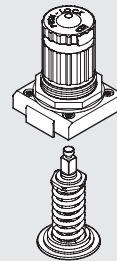

Code	Description
9210200	Bell 02 SY1
9210201	Bell 04 SY1
9210202	Bell 08 SY1
9210203	Bell 012 SY1
9210220	Bell 02 SY2
9210221	Bell 04 SY2
9210222	Bell 08 SY2
9210223	Bell 012 SY2
9210202X	Bell 08 SY1 anti-corrosion
9210203X	Bell 012 SY1 anti-corrosion
9210222X	Bell 08 SY2 anti-corrosion
9210223X	Bell 012 SY2 anti-corrosion

AC FILTERING ELEMENT (ACTIVE CARBON)

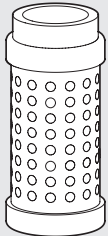

Code	Description
9210161	Cartridge AC SY1
9210166	Cartridge AC SY2

POPPET FOR REG

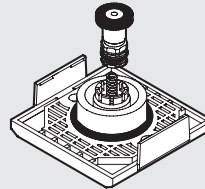

Code	Description
9210210	Poppet REG SY1
9210230	Poppet REG SY2
9210210X	Poppet REG SY1 anti-corrosion
9210230X	Poppet REG SY2 anti-corrosion

TRANSPARENT LUBRICATOR COVER

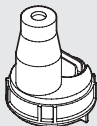

Code	Description
9210180	Transparent cover LUB SY1
9210185	Transparent cover LUB SY2

POPPET FOR FR

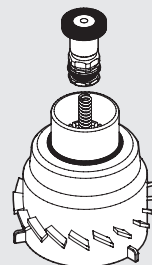

Code	Description
9210211	Poppet FR 5µm SY1
9210212	Poppet FR 20µm SY1
9210213	Poppet FR 50µm SY1
9210231	Poppet FR 5µm SY2
9210232	Poppet FR 20µm SY2
9210233	Poppet FR 50µm SY2

LUBRICATOR OIL-FILLING CAP

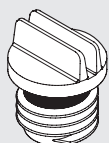

Code	Description
9210181	Oil-filling cap LUB SY1
9210186	Oil-filling cap LUB SY2

CNOMO CONTROL FOR V3V AND APR SY2

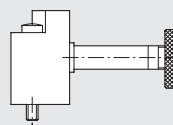

Code	Description
9453922	Elpn Cnomo control kit, manual bistable



