



C6

COMBICONTROL C6

MADE
IN
GERMANY



Automation





Found technical knowledge results in know-how. Industry experience leads to efficient and targeted engineering. Perfectly aligned products do their part for the benefit of our customers.

Extensive production depth, modern facilities, broad application knowledge, innovative products and more than 1,200 committed and motivated employees: All good reasons why the name KEB is also synonymous with optimum electronic, mechanical and electro-mechanical drive solutions.

Machines, systems and equipment: OEMs rely on KEB as a partner for applications in virtually all areas of machine and equipment building, as well as equipment, system and process technology.

This is where we are setting global standards, both in terms of function and quality. Working together to achieve optimum solutions. To achieve this objective, we work as a reliable and flexible partner all over the world. Production sites, marketing companies and representations in more than 30 countries ensure geographic proximity and rapid service routes to our customers.

Content	page
Automation and drives	2
KEB COMBIVIS studio 6	4
KEB COMBIVIS studio HMI	6
KEB COMBIVIS connect	8
KEB COMBICONTROL C6	10
C6 COMPACT	12
C6 HMI	14
C6 VISU	16
C6 ECON BOX IPC	18
C6 ECON PANEL IPC	20
C6 PERFORM BOX IPC	22
C6 PERFORM PANEL IPC	24
C6 Monitor	26
C6 Monitor vesa	28
C6 REMOTE I/O	30
KEB Addresses	36

We have a clearly formulated objective:

KEB wants to be a reliable, open and trustworthy partner to its clients. Therefore, when we speak of optimum drive technology solutions, we are focusing on the results that are the best fit for a particular situation. And for this reason we view the idea of partnership as the key to our success.

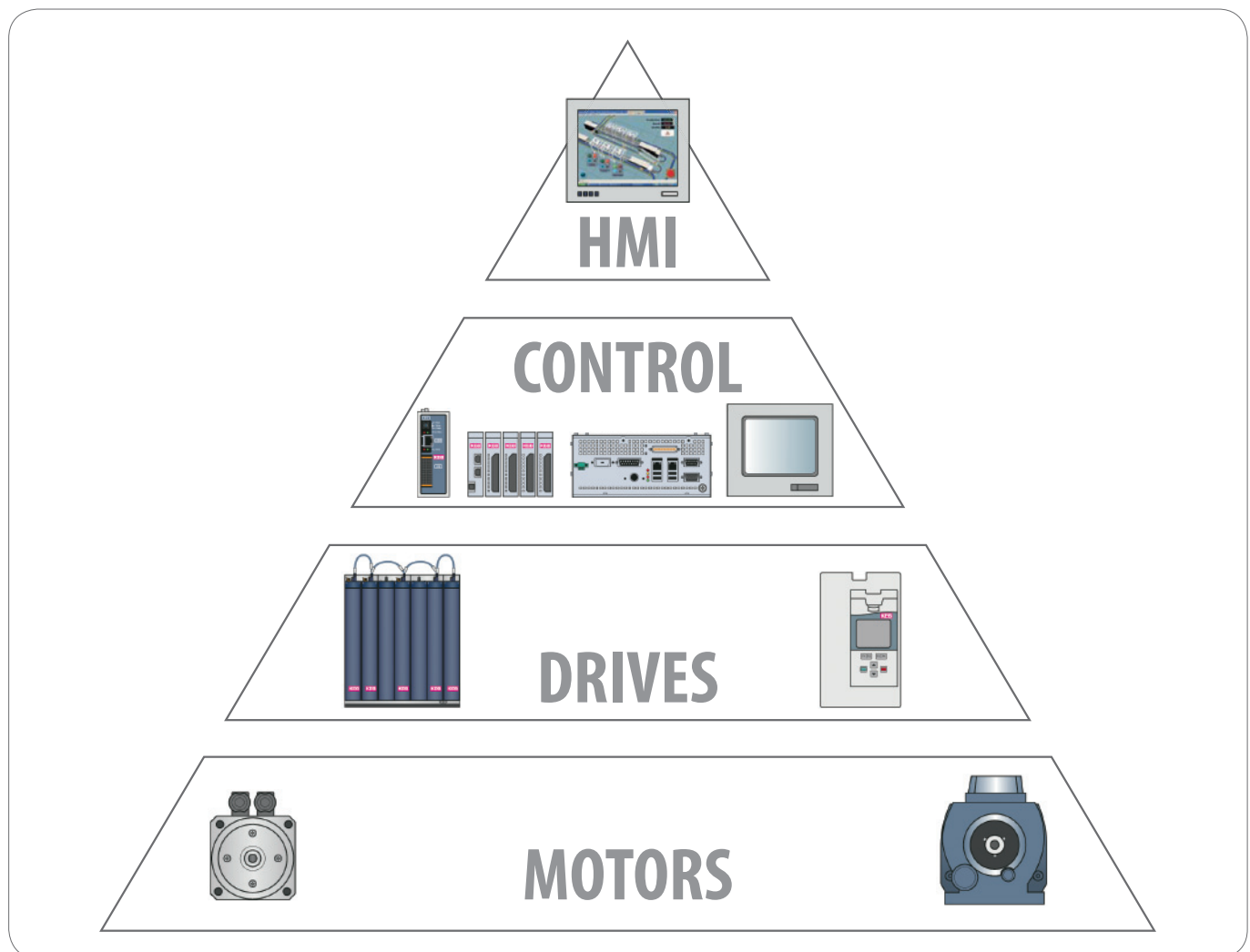

The KEB portfolio is based on the automation pyramid and consists of integrated powerful hardware and software solutions in the core segments

- Visualization
- PLC, motion and NC control
- single and multi axis drives with
- synchronous and asynchronous motors/geared motors

KEB COMBIVIS studio 6 - the innovative automation platform of the new generation

Programming, parametrisation and visualisation.



KEB COMBIVIS studio 6 combines drive parametrisation, IEC 61131-3 application development and HMI designer into a flexible tool that allows for highly efficient and customised application designs in the automation technology sector.

KEB COMBIVIS studio 6 is the entry-level option for programming pursuant to the international standard IEC 61131-3, which can be used for the independent and future-proof creation of your source code using a flexible selection of programming languages. Benefit from the comfortable „SmartCoding“ programming tools for declaration, error diagnostic, debugging and on-line data analysis purposes.

The KEB Soft-Motion and CNC libraries offer a direct entry into MOTION programming by implementing real-time-ready, synchronous drives and multi-axis systems.

Integrated editors assist with the creation of cam disk profiles, electronic gearheads, angular synchronous control and the inclusion of G-Code. KEB COMBIVIS studio 6 simplifies the simulation and visualisation of motion processes in office environments, as well as on-site start-up and equipment optimisation.

Intuitive start-up assistants, a digital 16-channel oscilloscope, tools for data back-up and restoration, and extensive expert settings for better optimising the fine-tuning of your system round off a future-oriented tool from the development of your automation system to after-sales service at the machine.

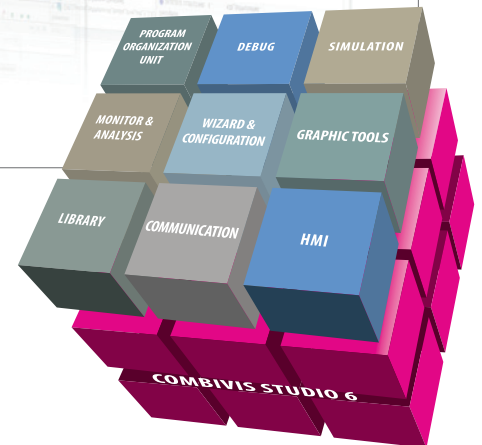

Test the COMBIVIS studio 6 version today and visit us a

Functions COMBIVIS studio

Basic Features	Object-oriented project management	<ul style="list-style-type: none"> Bus configuration (EtherCAT, CAN, ModBus, and weitere...) Configuration of Remote I/O s Portability of applications/ POU's/ IEC code to different targetsystems Several PLCs in one project
	Parameterizing	<ul style="list-style-type: none"> Drive setup, parameterizing and diagnostic of KEB COMBIVERT F5/B6/G6/H6/P6 and KEB COMBICONTROL C5/C6 Down-/ upload/ management of parameterlists Digital 16-channel oscilloscope Device search via Ethernet IP Scan/ Serial Scan/ EtherCAT Scan
	Integrated wizard	<ul style="list-style-type: none"> · Projekt-Startup · PD-Mapping Wizard · Velocity-Mode Wizard · EtherCAT Diagnosis Wizard · ... · Motor Configurator · Statemachine Wizard · Protection Wizard · FlashFile System Wizard
	Update	Internet update function
Programming	IEC61131-3 editors	<ul style="list-style-type: none"> · ST, AWL, · LD, SFC, FBD · CFC,SFC
	Smart-Coding	<ul style="list-style-type: none"> Input assistant, Auto-Declare IntelliSense Autoformat ...
	Debugging	<ul style="list-style-type: none"> Online Force/ Write Breakpoints Crossreference list Watch Windows CallStack ...
	Libraries	<ul style="list-style-type: none"> · Standard · KEB_Drive_Utility · KEB_SMC_Utility · PLC Hardware Library · CNC_Basic · Util · KEB_Gateway_Utility · KEB_Tools · SM3_Basic · ...
	SoftMotion and CNC support	<ul style="list-style-type: none"> · Single and multi-axis motion function blocks · Camcurve, electronical gear, phasing · Several cinematics · Integrated camcurve editor · Tappet generator · G-Code editor · VISU templates
	Integrated editor for visualization (HMI)	<ul style="list-style-type: none"> · Inline Service Visu · Target Visu · KEB COMBIVIS studio HMI

KEB COMBIVIS studio HMI - Visualisation at the highest level

Visualize and operate.



KEB COMBIVIS studio HMI is a powerful extension of the automation platform.

The special feature of this platform is the universality and portability of visualisation projects, which can be used both with WinCE as well as Win32 systems, and also support automatic scaling for different display sizes.

Two run-time versions, BASIC and ADVANCED, are available for the WinCE operating system. The Win32 operating system comes in three versions - BASIC, PRO and ADVANCED - which guarantee an optimum functional scope for any system.

6

The **BASIC version** includes all necessary functions for developing an HMI project with a limited amount of variables compared to other models.

The **PRO version** is suited for the development of more elaborate projects which require the storage of production data and alarms in local or off-site databases.

The **ADVANCED version** also offers the additional function of a web server that provides external access to the HMI project and sends SMS or e-mails as part of the alarm handling process.

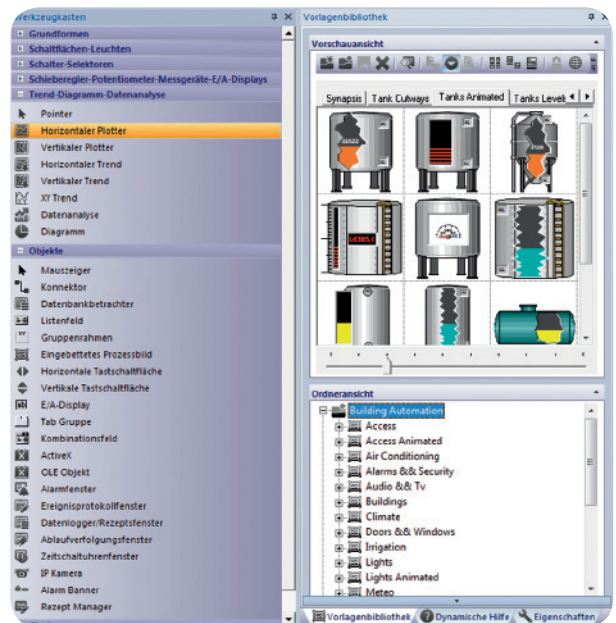

KEB is proud to present a technology that allows for the development of HMI solutions at the highest standard with the simplest application of your functionality, and whose performance meets all of the requirements of the new HMI age. Benefit from an extensive template library and a sophisticated tool box with scalable elements. Use the proven Drag&Drop principle to design multi-channel trends, alarm handling, data logger and customisable measurement and display instruments, and assign the data exchange using the importable PLC database.

Functions COMBIVIS studio HMI		BASIC WinCE	ADVANCED WinCE	BASIC Win32	PRO Win32	ADVANCED Win32	
Licenses		max. 512 byte	max. 4096 byte	max. 2048 byte	max. 2048 byte	max. 4096 byte	
Real Time	RealTime DB	•	•	•	•	•	
	Scaling	•	•	•	•	•	
	ODBC Realtime	•	•	–	•	•	
	Trace DB	•	•	–	•	•	
	Data Structures	•	•	•	•	•	
	Event Object	•	•	–	•	•	
Graphic Interface	Scaling Object	•	•	•	•	•	
	Vectorial Graphic Editor	•	•	•	•	•	
	Support for BMP, GIF, JPG, WMF, EMF	•	•	•	•	•	
	Dynamic Animation	•	•	•	•	•	
	Symbols Library	•	•	•	•	•	
	Import/Export Symbols	•	•	•	•	•	
	Public Symbols	•	•	–	•	•	
	Power Template (VBA Symbols)	•	•	–	•	•	
	Grid	•	•	–	•	•	
	Scheduler	•	•	•	•	•	
	Editing Menu	•	•	•	•	•	
	Style Source Management in Symbols	•	•	–	•	•	
	Dundas Gauge	–	–	•	•	•	
	IP Camera Viewer	•	•	•	•	•	
	Alias Management in Objects	•	•	–	•	•	
	Alarms Management	•	•	•	•	•	
	Historical Management (XML)	•	•	•	•	•	
	Historical Management (ODBC)	•	•	–	•	•	
	Alarms notification (SMS, Email, Voice)	–	•	–	–	•	
	Alarms area	•	•	•	•	•	
	Comments on alarm ACK	•	•	–	•	•	
	Schedulers objects	•	•	•	•	•	
	Data	Recipes / Data Logger (XML)	•	•	max. 2	•	•
		Recipes / Data Logger (ODBC)	max. 2	•	–	•	•
Textual Report		•	•	•	•	•	
Trends	Trend RealTime	•	•	•	•	•	
	Historical Trends on file .CVS	•	•	•	•	•	
	Historical Trends (linked to Data Logger XML)	•	•	•	•	•	
	Historical Trends Database (ODBC)	•	•	–	•	•	
	Data Analysis	•	•	–	•	•	
User	Use 1024 levels	•	•	•	•	•	
	Users Groups	•	•	•	•	•	
	CFR21	•	•	–	•	•	
	Runtime Users	•	•	•	•	•	
Driver	Max. Number of Driver	max. 2	max. 4	max. 2	max. 2	max. 4	
	PLC Tag Importer	•	•	•	•	•	
	OPC Client DA	•	•	•	•	•	
	OPC Client XML DA	–	–	•	•	•	
Logic	IL Logic (Step5–Step7)	•	•	•	•	•	
	VBA Logic (WinWrap Basic)	•	•	reduziert (max. 2)	•	•	
	Sinapsis Logic	•	•	–	•	•	
	Tag in IntelliSense in Basic Script	•	•	–	•	•	
Various	Networking	•	•	•	•	•	
	Dynamic multilanguage	•	•	•	•	•	
	Unicode support	•	•	•	•	•	
	Child Projects	•	•	–	•	•	
	Screens navigation	•	•	–	•	•	
	Visual Studio SourceSafe 2005 Integration	•	•	•	•	•	
	Web Client	–	•	–	–	•	
	Touch Screen support	•	•	•	•	•	
	Cross Reference	•	•	•	•	•	
	Debugger	•	•	•	•	•	

Supported Driver: KEB Devices, third Parties PLC, inverter and temperature controller

Remote maintenance

COMBIVIS connect is the innovative software solution for the remote access and remote maintenance of PC-based industrial machines with Windows operating systems (WinCE and Win32/64 environments).

- COMBIVIS connect Client: Software application on the office PC (Supervisor)
- COMBIVIS connect Runtime: Software components on the remote PC/Router

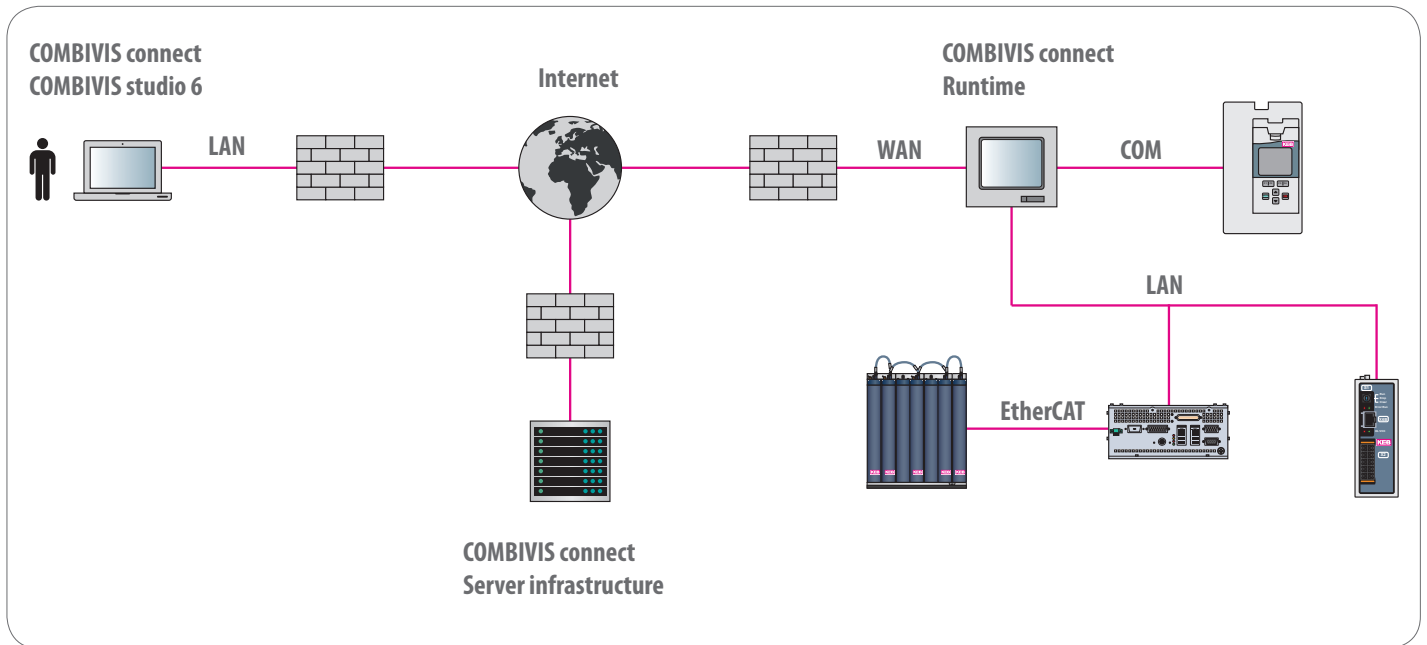

The new COMBIVIS connect product creates a VPN (Virtual Private Network) between office computers and remote devices and guarantees access to remote sub-networks.

8

Security

The COMBIVIS connect infrastructure meets the highest security standards.
The SSL/TLS protocol guarantees the highest degree of security and data protection.

Objective

Remote access and remote control make it possible to bridge small and large distances and reduce the incidence of technical travel.

This reduces costs and minimises time requirements with regard to response and problem-solving processes.

Application areas

- Monitoring of remote equipment
- Remote error search in control and other remote equipment
- Preventative and anticipatory maintenance
- Updating and modification of applications on remote controls

Functions of COMBIVIS connect

	WinCE	Win32/64
Remote Desktop	X	X
File / task manager	X	X
Chat, Screenshot	X	X
VPN up to remote PC	X	X
VPN with access to the remote PC ethernet subnet	X	X
Remoted serial (no MPI)	No	X
API for customer applications interface	X	X
Domain creation, users account and remote PC organization structured	X	X
Automatic connection	X	X

Advantages of COMBIVIS connect

- No need for additional hardware
- No need for network configuration
- Uses existing internet connection, remote PC does not require any services (VNC, FTP server etc.).

Why COMBIVIS connect?

- Complete and powerful remote maintenance option
 - ✓ Remote control of HMI
 - ✓ Remote access to equipment systems and sub-networks (automation network)
 - Ethernet via „end-to-end“ VPN
 - Serial via virtual serial port (pass-through mode)
 - ✓ additional tools
 - Remote desktop, file manager, chat, screen shots, task manager
- Secure and rapid through „end-to-end“ VPN
- Cost-effective, since no additional hardware is required
- Simple set-up

KEB COMBICONTROL C6

KEB COMBICONTROL C6 is the automation platform that focuses on dynamic and drive-oriented applications with motion control in the machine and equipment building sector. Scalable and tailored to your requirements, this control technology, which was designed with embedded and IPC versions, offers a broad platform for a variety of tasks.

The KEB COMBIVIS studio 6 automation tool is the new software environment, freely programmable pursuant IEC 61131-3.



RTE

RTE: Forms the basis for PLC and motion control functionality.
This symbol is placed on the available hardware.



BASIC Basic functional scope for the KEB automation platform.
(IEC 61131-3 standard and KEB Basic libraries)



PRO Professional functional scope for the KEB automation platform.
(cam disks, electronic gearheads, angular synchronous control)



ADVANCED Advanced functional scope for the KEB automation platform.
(CNC functionality, G-Code, prepared kinematics)



HMI

HMI: Forms the basis for visualisation and operating tasks.
This symbol is placed on the available hardware.



BASIC Basic functional scope for the KEB HMI.



PRO Professional functional scope for the KEB HMI.
(expanded real-time bank, data logger)



ADVANCED Advanced functional scope for the KEB HMI.
(web server, multi drivers, SMS, e-mail)



Connect

CONNECT Forms the basis for professional remote maintenance.
This symbol is placed on the available hardware.

KEB COMBICONTROL C6 COMPACT

is the embedded control for an all-in-one solution in smaller machines or an especially cost-effective motion control solution subordinate to conventional PLC controls.

KEB COMBICONTROL C6 HMI

allows an high-quality visualisation and operation of your application, and offers a cost-effective solution despite its extensive scope of services. High resolutions and attractive optics highlight the best features of your system.

KEB COMBICONTROL C6 VISU

is an IPC-based control and visualisation solution that features flexible interfaces and an impressive functional scope. This system provides a platform for the optimum and lucrative solution for implementing your objectives.

KEB COMBICONTROL C6 ECON

is the entry into IPC- and Windows-based technology that already offers all of the required characteristics for dynamic motion tasks in machines and the complete control of systems in its basic version.

KEB COMBICONTROL C6 PERFORM

is designed for the implementation of automation tasks for the most demanding requirements and encompasses the peak performance of the IPC platform for integrated motion control and visualisation in one hardware.

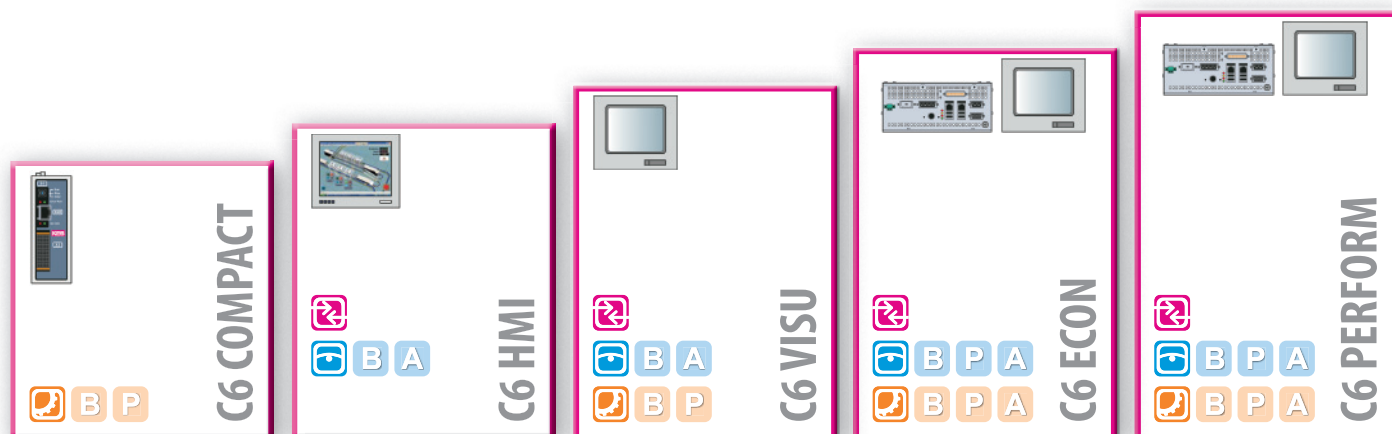

KEB COMBICONTROL C6 COMPACT

C6 COMPACT is a compact control whose functionality and performance are designed to coordinate and synchronise the motion processes of multiple axes.

The integrated EtherCAT Master provides a rapid real-time bus system that in combination with computing performance and software functionalities represents a truly powerful and cost-effective system.

Equipped with all possible options, the C6 COMPACT can assume control of your entire system or merely look after the motion processes of your application as a subordinate system with numerous interfaces such as Profibus, CAN, Interbus and Ethernet.

This efficient concept without a superimposed operating system uses the entire computing performance for the application of Soft PLC and motion tasks and allows for cycle times starting at 1 ms. The C6 COMPACT is full of possibilities, and offers a cost-effective system for solving your requirements notwithstanding its flexibility and high performance.



C6 COMPACT

Dimensions	125 x 44 x 144 mm
Weight	approx. 260 g
Installation method	35 mm Mounting rail
Grounding	via terminal strip or plug-in contact
Type of protection	IP20
Operating temperature	-10...45 °C
Storage temperature	-25...70 °C
Climatic category (EN60721-3-3)	3K3
Environment (IEC664-1)	pollution degree 2
Operation voltage control (Us)	18...30 V DC ±0 %
Power input control	3 W max.
Wiring system	cage-clamp terminals
Operation voltage inputs/outputs (Um)	18...30 V DC ±0 %
Output current	0.7 A per channel, short-circuit proof, free wheeling diode integrated
Input voltage/current	according IEC 61131-2 Type 1

CPU	SH7269 - 32-Bit RISC micro computer SuperHTM RISC engine incl. floating point unit
Memory	Code + Data 256 MB Retain Memory 32 KB
Interfaces	1 x Ethernet 10/100 Mbit/s 1 x EtherCAT Master 1 x RS232/485 4 x KEB HSP5 4 x digital input (1 x faster input: 100 µs) 4 x digital output (24 V; 0.7 A)

OPTIONS

Bus system	Profibus slave interface	
	CAN slave interface	
	Interbus slave interface	
Licenses	RTE BASIC	X
	RTE PRO	

KEB COMBICONTROL C6 HMI

The C6 HMI series meets the most demanding requirements in terms of visualisation, operation and functionality. Its attractive design and high-quality display form the basis for sophisticated visualisation processes.

In combination with the professional COMBIVIS studio HMI visualisation tool, it is possible to implement human-machine interfaces according to the latest state of technology

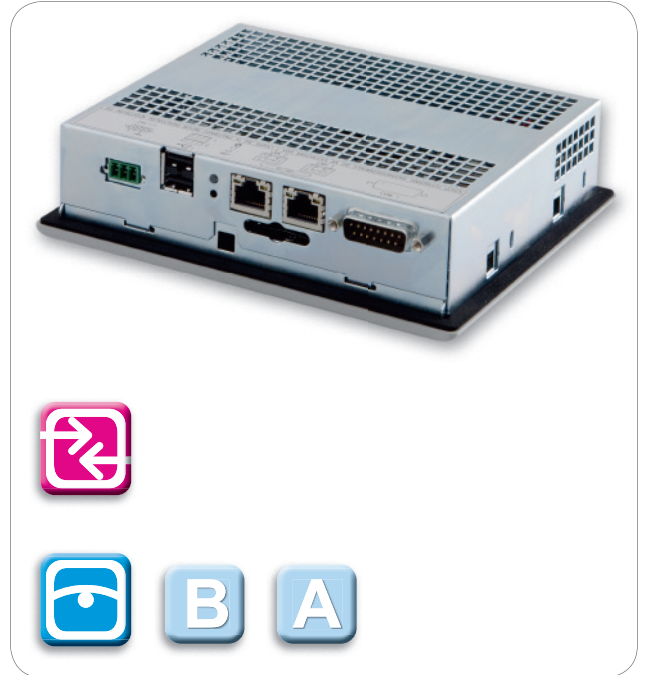

C6 HMI

CPU	ARM Cortex A8 processor · Freescale i.MX535 · 1 GHz · 400 Mhz memory bus
RAM	512 MB RAM
Graphic	GPU with integrated LCD controller
Interfaces	1 x RS232/422/485 (DB15M) 2 x 10/100 Mbps (RJ45) (4.3" 1 x 10/100Mbps (RJ45)) 2 x USB (4.3" 1 x USB)
Mass storage	NAND-Flash 256 MB Read-Only · for operating system and run-time environment eMMC (Solid State Disc) 2 GB, 8 bit, File System organization External Access SD/SDHC card slot from size 5,7"
Operation voltage	Input voltage 18-36 V DC
Temperature	Operation 0 - 50 °C without HDD Storage -20 - 60 °C Humidity: 80% (non-condensing)
Protection class	IP 65 aluminum front panel

Display & Touch Screen	4.3" LCD TFT · VGA, 480x272, 16M colors · backlight LED, 500 cd/m2 · viewing angle: 140° (H), 90° (V) Touch screen · 4 wires resistive technology · (140 x 95 x 30 mm)	
	5.7" LCD TFT · VGA, 640x480, 16M colors · backlight LED, 500 cd/m2 · viewing angle: 140° (H), 100° (V) Touch screen · 4 wires resistive technology · (175 x 145 x 40 mm)	
	7" WIDE LCD TFT · WVGA, 800x480, 256K colors · backlight LED, 350 cd/m2 · viewing angle: 140° (H), 130° (V) WIDE Touch screen · 4 wires resistive technology · (215 x 155 x 40 mm)	
	8.4" LCD TFT · SVGA, 800x600, 16M colors · backlight LED, 350 cd/m2 · viewing angle: 150° (H), 130° (V) Touch screen · 5 wires resistive technology · (255 x 190 x 48,5 mm)	
	10.4" LCD TFT · SVGA, 800x600, 16M colors · backlight LED, 400 cd/m2 · viewing angle: 160° (H), 140° (V) Touch screen · 5 wires resistive technology · (295 x 230 x 48,5 mm)	
	12.1" LCD TFT · SVGA, 800x600, 256K colors · backlight LED, 450 cd/m2 · viewing angle: 160° (H), 140° (V) Touch screen · 5 wires resistive technology · (325 x 260 x 48,5 mm)	
	15" LCD TFT · XGA, 1024x768, 16M colors · backlight LED, 400 cd/m2 · viewing angle: 160° (H), 145° (V) Touch screen · 5 wires resistive technology · (390 x 305 x 48,5 mm)	

OPTIONS

Licenses	HMI BASIC WIN CE, Connect runtime WIN EC7	X
	HMI ADVANCED, Windows Embedded Compact 7, Connect runtime WIN EC7	

KEB COMBICONTROL C6 VISU

The C6 VISU series has been prepared for the specific requirements that apply to visualisation tasks, and it forms the human-machine interface in a variety of applications.

An attractive design, high-quality materials combined with extensive functionality at a reasonable cost.

In combination with realtime software the IPC serves typical control and motion tasks in smaller machines

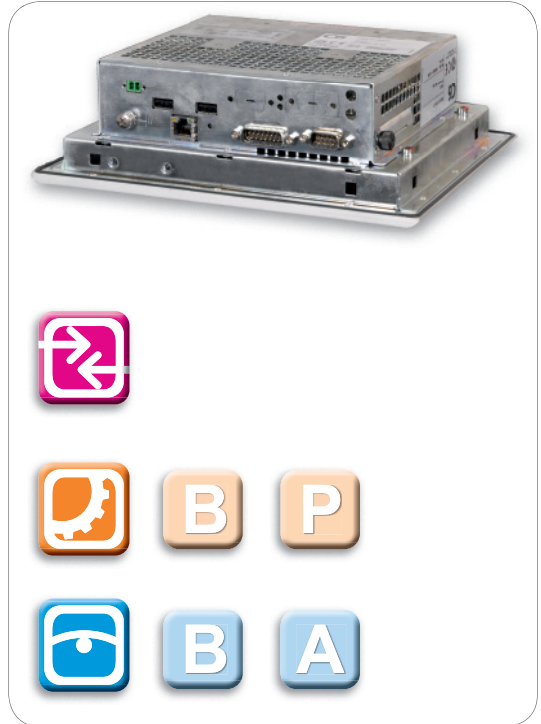

C6 VISU

CPU	AMD Geode LX800 500 MHz · Fanless
RAM	512 MB · DDR SODIMM (1 Module) · PC2700
Graphic	On-board mit LVDS Digital I/F / 128 MB system selectable
Interfaces	1 x RS232 (DB9-M) 1 x RS232/422/485 (DB15M) 1 x 10/100 Mbps (RJ45) 2 x USB 2.0 rear 1 x USB
Compact Flash	1 x Type II (internal access), 1 x Type II (external access)
Expansion slot	2 x MiniPCI Type III
Operation voltage	Input voltage 18-36 V DC
Temperature	Operation 0 - 50 °C Storage -20 - 60 °C Humidity: 80% (non-condensing)
Protection class	IP 65 aluminum front panel

Box IPC	C6 VISU Box IPC · without display for wall and DIN rail mounting · (221 x 163 x 61 mm)	
Panel IPC	Touch-Screen LCD TFT 6.5" VGA, 640x480, 256K colors · backlight LED, 800 cd/m ² · viewing angle: 160° (H), 140° (V) · 4-wires resistive technology · (201 x 168 x 68 mm)	
	Touch-Screen LCD TFT 8.4" VGA, 800x600, 256K colors · backlight LED, 400 cd/m ² · viewing angle: 120° (H), 100° (V) · 5-wires resistive technology · (240 x 202 x 73 mm)	
	Touch-Screen LCD TFT 12.1" VGA, 800x600, 256K colors · backlight LED, 450 cd/m ² · viewing angle: 160° (H), 140° (V) · 5-wires resistive technology · (321 x 262 x 73 mm)	

OPTIONS

Boards	EtherCAT	
	Dual CAN Mastercard	
	512 KB NVRAM	
Licenses	HMI BASIC WIN CE, Compact Flash 2 GB, WIN CE real time	X
	HMI ADVANCED WIN CE	
	RTE BASIC WIN CE	
	RTE PRO WIN CE	
	Connect runtime WIN CE	

KEB COMBICONTROL C6 ECON BOX IPC

The Box IPC C6 ECON features a high level of performance and diversity. Especially developed for industrial applications, the C6 ECON impresses with its lean design and extensive availability over many years.

Perfectly aligned to the runtime environment and real-time capacity, this system is the answer for tasks with demanding performance requirements that must also be cost-effective. The option to add a UPS system opens up many new possibilities in cases of operating voltage failures.

- VGA
- WIN XPe
- DIN RAIL WALL
- 24VDC UPS
- USB/CFC
- fanless



C6 ECON BOX IPC

CPU	Intel Celeron 373 M ULV · 1GHz, 400MHz front side bus, 512 KB cache, fanless
RAM	1 GB · 1 SODIMM Module DDR2 PC6400
Graphic	GMA900 integrated in Intel® 915GME Shared - 64 MB÷128 MB system selectable
Interfaces	1 x RS232 (DB9-M) 1 x PS/2 Keyboard / Mouse 2 x 10/100/1000 Mbps (RJ45) 4 x USB 2.0 1 x analog VGA (DB15-F, max resolution 2048x1536 QXGA)
Compact Flash	1 x Type I (internal access), 1 x Type II (external access)
Expansion slot	1x PC/104 Plus or 1 x PCI half size
Operation voltage	Input voltage 18-36 V DC
Temperature	Operation 0 - 50 °C without HDD, 0 - 45 °C with HDD Storage -20 - 60 °C Humidity: 80% (non-condensing)
Protection class	IP20 Nickel treated metal housing
Dimensions	252 x 190 x 90 mm

OPTIONS









Operation voltage	Uninterruptible power supply (UPS) · 15 minutes of backup time · equipped with batteries · mounted on the rear side of the housing	
Bus system	EtherCAT	X
	Dual CAN Mastercard	
Mass storage	NVRAM 512 KB	
	HDD Hard Disk 250 GB	
	HDD Hard Disk 500 GB	
	SSD – solid state disk 4 GB	
	SSD – solid state disk 8 GB	
	SSD – solid state disk 16 GB	
	SSD – solid state disk 32 GB	
Licenses	RTE BASIC WIN 32, Compact Flash 2 GB, Windows XPe real time	X
	RTE PRO WIN 32	
	RTE ADVANCED WIN 32	
	HMI BASIC WIN 32	
	HMI PRO WIN 32	
	HMI ADVANCED WIN 32	
	Connect runtime WIN 32	

KEB COMBICONTROL C6 ECON PANEL IPC

With the same properties as the BOX IPC, the C6 ECON PANEL IPC is an all-round talent that combines operation and control of an application in one unit with an integrated monitor.

This system allows for sophisticated graphics with touch control, and forms the human-machine interface according to the latest state of technology.



 8,4" 10,4" 12,1" 15" 17" 19"	 VGA	
 Touch	 Panel	 24VDC UPS
 WIN XPe	 USB/CFC	 fanless

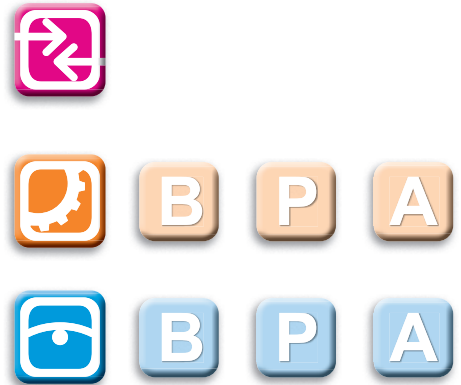

C6 ECON PANEL IPC

CPU	Intel Celeron 373 M ULV · 1GHz, 400MHz front side bus, 512 KB cache, fanless
RAM	1 GB · 1 SODIMM Module DDR2 PC6400
Graphic	GMA900 integrated in Intel® 915GME Shared - 64 MB-128 MB system selectable
Interfaces	1 x RS232 (DB9-M) 1 x PS/2 Keyboard / Mouse 2 x 10/100/1000 Mbps (RJ45) 4 x USB 2.0, 1 x USB 2.0 front access 1 x analog VGA (DB15-F, 2048 x 1536 QXGA)
Compact Flash	1 x Type I (internal access), 1 x Type II (external access)
Expansion slot	1x PC/104 Plus or 1 x PCI half size
Operation voltage	Input voltage 18-36 V DC
Temperature	Operation 0 - 50 °C without HDD, 0 - 45 °C with HDD Storage -20 - 60 °C Humidity: 80% (non-condensing)
Protection class	IP65 aluminum front panel with polycarbonate front foil
Touch Screen Display	Touch-Screen 8.4" · 5-wires resistive technology · SVGA, 800x600, 16M colors · LED, 450 cd/m2 · viewing angle: 100° (H), 140° (V) · (250 x 210 x 103 mm)
	Touch-Screen 10.4" · 5-wires resistive technology · SVGA, 800x600, 256K colors · 2 lamps, 400 cd/m2 · viewing angle: 120° (H), 100° (V) · (300 x 245 x 103 mm)
	Touch-Screen 12.1" · 5-wires resistive technology · SVGA, 800x600, 16M colors · LED, 500 cd/m2 · viewing angle: 160° (H), 140° (V) · (335 x 270 x 103 mm)
	Touch-Screen 15" · 5-wires resistive technology · XGA, 1024x768, 16M colors · LED, 450 cd/m2 · viewing angle: 160° (H), 140° (V) · (390 x 315 x 103 mm)
	Touch-Screen 17" · 5-wires resistive technology · SXGA, 1280x1024, 16M colors · 2 lamps, 300 cd/m2 · viewing angle: 160° (H), 160° (V) · (455 x 355 x 103 mm)
	Touch-Screen 19" · 5-wires resistive technology · SXGA, 1280x1024, 16M colors · 2 lamps, 300 cd/m2 · viewing angle: 160° (H), 160° (V) · (490 x 388 x 113 mm)

OPTIONS

Operation voltage	Uninterruptible power supply (UPS) · 15 minutes of Back-up time · equipped with batteries · mounted on the rear side of the housing	
Bus system	EtherCAT	X
	Dual CAN Mastercard	
Mass storage	NVRAM 512 KB	
	HDD Hard Disk 250 GB	
	HDD Hard Disk 500 GB	
	SSD – solid state disk 4 GB	
	SSD – solid state disk 8 GB	
	SSD – solid state disk 16 GB	
	SSD – solid state disk 32 GB	
Licenses	RTE BASIC WIN 32, Compact Flash 2 GB, Windows XPe real time	X
	RTE PRO WIN 32	
	RTE ADVANCED WIN 32	
	HMI BASIC WIN 32	
	HMI PRO WIN 32	
	HMI ADVANCED WIN 32	
	Connect runtime WIN 32	

KEB COMBICONTROL C6 PERFORM BOX IPC

The C6 PERFORM easily meets the most demanding requirements for visualisation and control tasks, and features powerful computing performance and graphics functionality.

The available process sorting types offer the right performance for a variety of applications. A powerful IPC platform that comes with a large number of options is capable of implementing many different tasks.



C6 PERFORM BOX IPC

CPU	Intel Pentium T4500 dual core · 2.3GHz, 800 MHz front side bus, 1 MB cache
RAM Memory	1 GB · 1 SODIMM Module DDR2 PC6400
CPU	Intel Core 2 Duo T6400 · 2GHz, 800 MHz front side bus, 2 MB cache
RAM Memory	2 GB · 1 SODIMM Module DDR2 PC6400
Graphic	Intel® GMA X3100 (integrated in-chip Intel® 965 GME)
Interfaces	2 x RS-232 DB9 male connector 2 x PS/2 Keyboard / Mouse 2 x 10/100/1000 Mbps (RJ45) 4 x USB 2.0 standard A Connector 1 x VGA analog (DB15F - max resolution 2048x1536 QXGA 60Hz) 1 x DVI-D (max resolution 1600x1200 UXGA)
Compact Flash	1 x Compact Flash Type II slot, rear
Expansion slot	up to 3 x PCI, 1 x PCI-Express x 4 format half size · on riser card
Operation voltage	Input voltage 18-36 V DC
Temperature	Operation 0 - 50 °C without HDD, 0 - 45 °C with HDD Storage -20 - 60 °C Humidity: 80% (non-condensing)
Protection class	IP20 Nickel treated metal housing
Dimensions	370 x 236 x 117 (60.5) mm

OPTIONS

Bus system	EtherCAT	X
	Dual CAN Mastercard	
Mass storage	NV RAM 512 KB	
	HDD Hard Disk 250 GB	
	HDD Hard Disk 500 GB	
	SSD – solid state disk 4 GB	
	SSD – solid state disk 8 GB	
	SSD – solid state disk 16 GB	
Licenses	RTE BASIC WIN 32, Compact Flash 2 GB, Windows XPe real time	X
	RTE PRO WIN 32	
	RTE ADVANCED WIN 32	
	HMI BASIC WIN 32	
	HMI PRO WIN 32	
	HMI ADVANCED WIN 32	
	Connect runtime WIN 32	

Industrial PCs from the C6 PERFORM series meet all of the requirements of present and future automation technology.

This flexible high-end device class allows for the comprehensive visualisation of a system as well as the precise calculation of highly dynamic processes in one device. In this manner, it guarantees the optimum hardware and software structure for the machine.

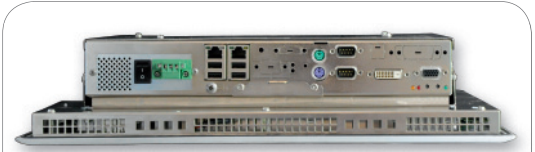

C6 PERFORM PANEL IPC

CPU	Intel Pentium T4500 dual core · 2.3GHz, 800 MHz front side bus, 1 MB cache
RAM Memory	1 GB · 1 SODIMM Module DDR2 PC6400
CPU	Intel Core 2 Duo T6400 · 2GHz, 800 MHz front side bus, 2 MB cache
RAM Memory	2 GB · 1 SODIMM Module DDR2 PC6400
Graphic	Intel® GMA X3100 (integrated in-chip Intel® 965 GME)
Interfaces	2 x RS-232 DB9 male connector 2 x PS/2 Keyboard / Mouse 2 x 10/100/1000 Mbps (RJ45) 2 x USB 2.0 standard front access , 4 x USB 2.0 standard rear 1 x VGA analog (max resolution DB15F - 2048x1536 QXGA 60Hz) 1 x DVI-D (max resolution 1600x1200 UXGA)
Compact Flash	1 x Compact Flash Type II slot, rear
Expansion slot	up to 3 x PCI, 1 x PCI-Express x4 format half size on riser card
Operation voltage	Input voltage 18-36 V DC
Temperature	Operation 0 - 50 °C without HDD, 0 - 45 °C with HDD Storage -20 - 60 °C Humidity: 80% (non-condensing)
Protection class	IP65 aluminum front panel with polycarbonate front foil
Touch Screen Display	Touch-Screen 12.1" · 5-wires resistive technology · SVGA, 800x600, 16M colors · LED, 500 cd/m2 · viewing angle: 120° (H), 100° (V) · (355 x 270 x 137 mm)
	Touch-Screen 15" · 5-wires resistive technology · XGA, 1024x768, 16M colors · LED, 450 cd/m2 · viewing angle: 160° (H), 140° (V) · (425 x 305 x 137 mm)
	Touch-Screen 17" · 5-wires resistive technology · SXGA, 1280x1024, 16M colors · 2 lamps, 300 cd/m2 · viewing angle: 150° (H), 150° (V) · (455 x 355 x 137 mm)
	Touch-Screen 19" · 5-wires resistive technology · SXGA, 1280x1024, 16M colors · 2 lamps, 300 cd/m2 · viewing angle: 160° (H), 160° (V) · (490 x 388 x 147 mm)

OPTIONS

Bus system	EtherCAT	X
	Dual CAN Mastercard	
Mass storage	NVRAM 512 KB	
	HDD Hard Disk 250 GB	
	HDD Hard Disk 500 GB	
	SSD – solid state disk 4 GB	
	SSD – solid state disk 8 GB	
	SSD – solid state disk 16 GB	
	SSD – solid state disk 32 GB	
Licenses	RTE BASIC WIN 32, Compact Flash 2 GB, Windows XPe real time	X
	RTE PRO WIN 32	
	RTE ADVANCED WIN 32	
	HMI BASIC WIN 32	
	HMI PRO WIN 32	
	HMI ADVANCED WIN 32	
	Connect runtime WIN 32	

KEB COMBICONTROL C6 Monitor

The C6 monitor series complements the BOX PCs with an industry monitor for visualisation and operation of the application.

Sizes based on latest technologies complement the program offered by KEB appealing design and various monitor sizes.

A front USB port, and two more on the back with integrated HUB belong to the standard equipment.

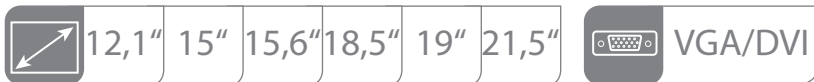

C6 MONITOR

Protection class	IP65 Aluminum front panel
Temperature	Operation 0...45 °C Storage -20...60 °C Humidity: 80 % (non-condensing)
Touch Screen	5 wires resistive technology
Interfaces	1 x VGA (DB15F) 1 x DVI Single Link Front 1 x USB 2.0 Rear 2 x USB 2.0, 1 x USB 2.0 (HUB input, Type B)
Operation voltage	24 V DC · 8...32 V DC
Touch Screen Display	LCD TFT 12.1" · XGA, 1024x768, 16M colors, backlight LED 600 cd/m ² viewing angle L:R / U:L: 80°:80° / 70°:70° · (W x H x D, 335 x 270 x 67 mm)
	LCD TFT 15" · XGA, 1024x768, 16M colors, backlight LED 400 cd/m ² viewing angle L:R / U:L: 80°:80° / 65°:80° · (W x H x D, 390 x 315 x 67 mm)
	LCD TFT 15.6" · WXGA(HD), 1366x768, 16M colors, backlight LED 300 cd/m ² viewing angle L:R / U:L: 85°:85° / 80°:80° · (W x H x D, 430 x 275 x 67 mm)
	LCD TFT 18.5" · WXGA(HD), 1366x768, 16M colors, backlight LED 300 cd/m ² viewing angle L:R / U:L: 170° / 160° · (W x H x D, 500 x 320 x 69 mm)
	LCD TFT 19" · SXGA(HD), 1280x1024, 16M colors, backlight LED 300 cd/m ² viewing angle L:R / U:L: 80°:80° / 80°:80° · (W x H x D, 490 x 388 x 67 mm)
	LCD TFT 21.5" · (FHD), 1920x1080, 16M colors, backlight LED 300 cd/m ² viewing angle L:R / U:L: 89°:89° / 89°:89° · (W x H x D, 579 x 367 x 69 mm)

OPTIONS

Cable set	Cable set 1.8 m VGA (VGA 1.8 m / USB 1.8 m)
	Cable set 1.8 m DVI (DVI 1.8 m / USB 1.8 m)
	Cable set 7.5 m VGA (VGA 10 m / USB 7.5 m)
	Cable set 7.5 m DVI (DVI 10 m / USB 7.5 m)
	Cable set 10 m VGA (VGA 10 m / USB 11 m reinforced)
	Cable set 10 m DVI (DVI 10 m / USB 11 m reinforced)

KEB COMBICONTROL C6 Monitor vesa

The C6 Monitor **vesa** offers customer-specific design for industrial applications. The optional extensions allow individual design of the human machine interface with an attractive design visualisation and operation of the application.

The remote option allows the transfer of the image, touch and USB data over long distances of up to 40 m.



C6 Monitor vesa

Monitor	LCD TFT 15" XGA 1024 x 768 16M colors, 400 cd/m ² viewing angle, L:R / U:L: 150° H / 135° V
Protection class	IP65 aluminum front panel with polycarbonate front foil
Temperature	Operation 0...45 °C Storage -5...60 °C Humidity: 80% (no condensation)
Touch Screen	5 wires resistive technology
Interfaces	1 x RJ45 (Integrated receiver module for VGA video and USB signals) Front 2 x USB 2.0 Rear 2 x USB 2.0, 1 x USB 2.0 (HUB input, Type B)
Operation voltage	24 V DC · 8...32 V DC
Dimensions	Monitor 400 x 335 x 50 mm · 8 kg
	Side module 150 x 335 x 50 mm · 2 kg
	Keyboard 400 x 180 x 37 mm · 3 kg

OPTIONS

Modules	Left side module · 2x4 Matrix · diameter Ø22 · labelling fields	
	Right side module · 2x4 Matrix · diameter Ø22 · labelling fields	
Keyboard	86-Key keyboard · international layout · Emergency preparation (diameter Ø22)	
	Keyboard protector cover skin	
Interface module Cable	1 x RJ45 (Amplifier module) · 2 x USB 1.1 · Cable set 0.9m VGA/USB	
	Cable 10 m · CAT6 SFTP	
	Cable 15 m · CAT6 SFTP	
	Cable 20 m · CAT6 SFTP	
	Cable 30 m · CAT6 SFTP	
	Cable 40 m · CAT5E FTP	



C6 MONITOR vesa

CAT5E / CAT6
40 m



Amplifier module

VGA
USB



C6 Box IPC

KEB COMBICONTROL C6 REMOTE I/O

Analog or digital - the acceptance and output of signals in the periphery of a system requires the decentralisation of joining technology and a suitable medium of signal transmission to central intelligence. The KEB REMOTE I/O system is based on the economically optimal Ethernet hardware and transfers the proven characteristics of real-time communication into each element of the input/output level using the EtherCAT protocol standard.

Mechanically assembled in a standardised 25 mm aluminium frame, this plug-in modular system meets the highest requirements for EMC immunity, and offers a high degree of packing density. Each bus coupler, as the head end of a decentralised unit, can connect up to 20 remote I/O modules with a maximum current drain of 3 A.

The efficient plug technology of the various modules allows for quick installation, extension or replacement with a standardised 35 mm DIN top-hat rail. The spring-loaded connectors of the connections feature a high service density and vibration resistance, and use a simple lever mechanism for dismantling purposes without requiring special tools.

Optional shield clamps available in 1x14 mm and 2x8 mm ensure good grounding and stress relief for the connected loads. The KEB REMOTE I/O system provides a powerful foundation for decentralised I/O connections in modular machine systems.

EtherCAT®

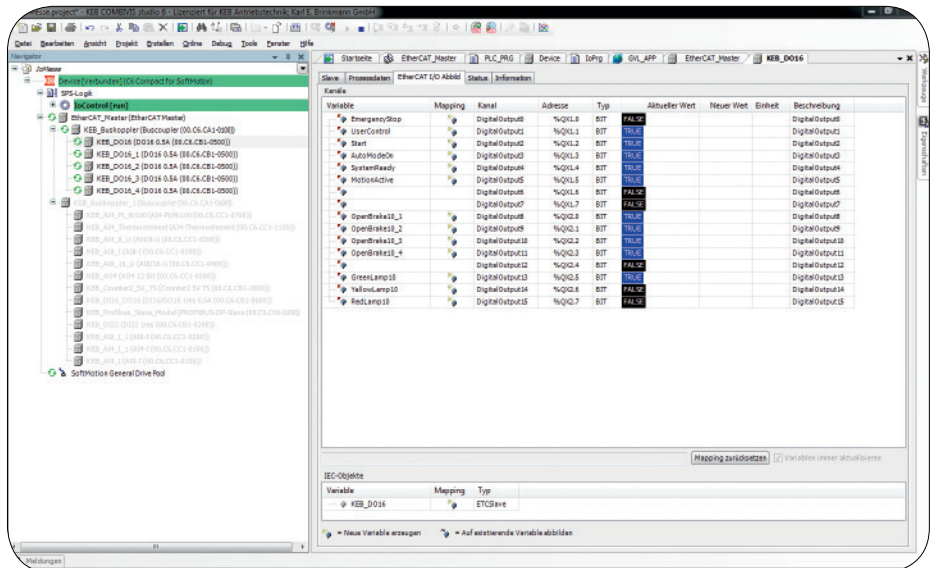

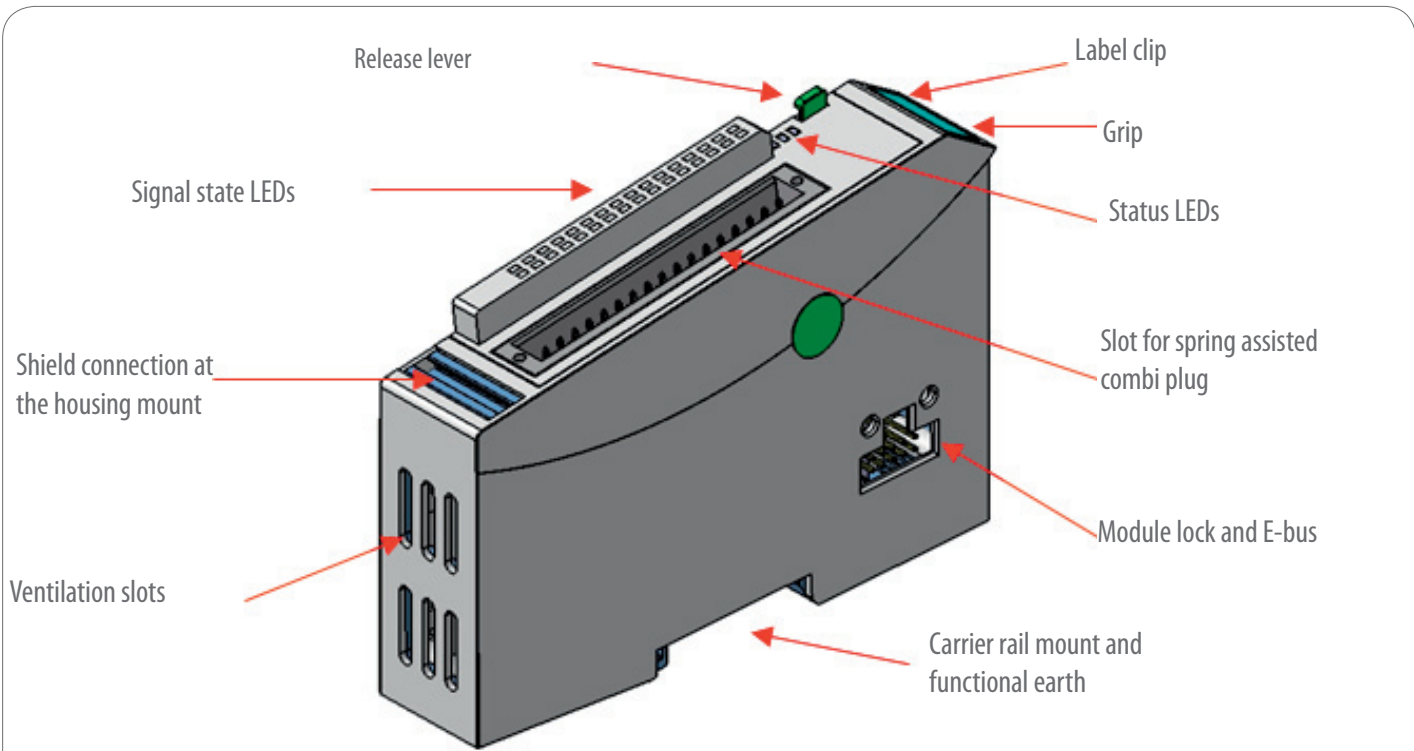

Fieldbus	EtherCAT 100 Mbits/s
W x H x D	25 x 120 x 90 mm
Montage	35 mm DIN mounting rail
Controller	ASIC ET 1100
Connection E-Bus	10-pin system connector in side panel
End module	not necessary
Operation voltage	24 V DC -20 % +25 %
Potential separation	Modules electrically insulated from one another and from the bus
Storage temperature	-25...+70 °C
Operating temperature	0...+55 °C
Relative humidity	5...95 %, non-condensing
Type of protection	IP20
Interference immunity	Zone B

KEB REMOTE I/O EtherCAT Shielding clamps

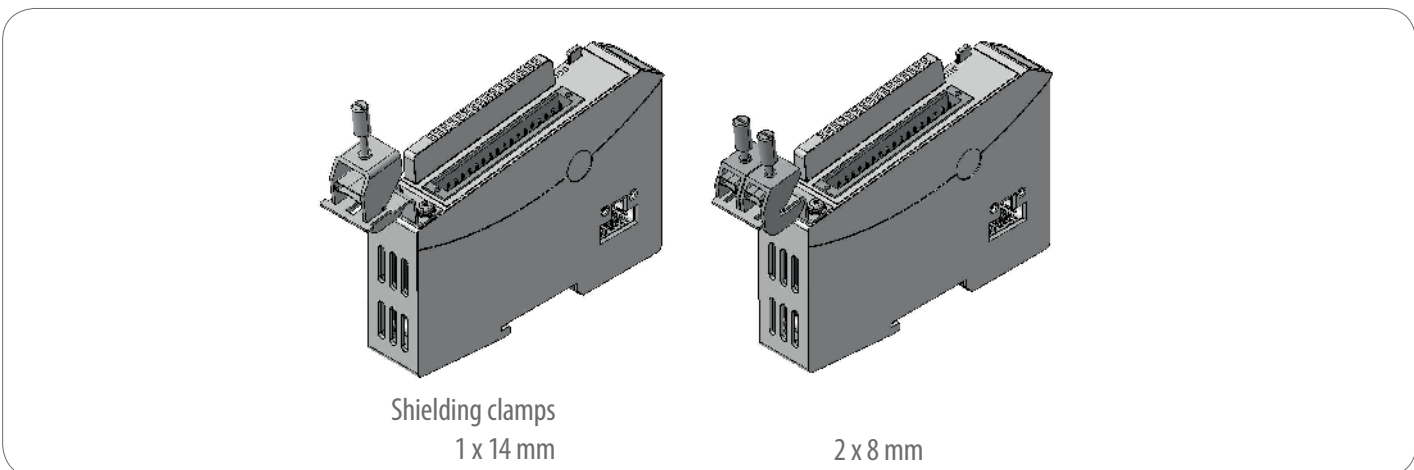

KEB REMOTE I/O EtherCAT Bus Coupler



Function	Connects a 100Base-TX EtherCAT with C6 Remote I/O modules, Generates LVDS system voltage
Controller	ASIC ET 1100
Baud rate	100Mbit/s
Cable	CAT5
Cable length	max. 100 m between two bus couplers
Connector	EtherCAT 2 x RJ45
Voltage supply	24 V DC -20 % +25 %
Connector Power	Plug 2-polig (part of the module)
Input current	50 mA + E-Bus power supply
E-Bus power supply	max. 3 A (approx. 20 modules)
E-Bus load	195 mA

KEB REMOTE I/O EtherCAT Digital I/O's



D116/D016	
Digital inputs	16
Input delay	1 ms
Signal level (EN 61131-3, Typ1)	Off: -3...5 V; On 15...30 V
Digital outputs	16
Max. current	0.5 A per output
Total current	max. 8 A
E-bus load	135 mA

D116	
Digital inputs	16
Input delay	1 ms
Signal level (EN 61131-3, Typ1)	Off: -3...5 V; On 15...30 V
E-bus load	100 mA

D016	
Digital outputs	16
Max. current	0.5 A per output
Total current	max. 8 A
E-bus load	130 mA

D132	
Digital inputs	32
Input delay	1 ms
Signal level (EN 61131-3, Typ1)	OFF: -3...5 V; ON 15...30 V
E-bus load	85 mA

KEB REMOTE I/O EtherCAT Analog IN

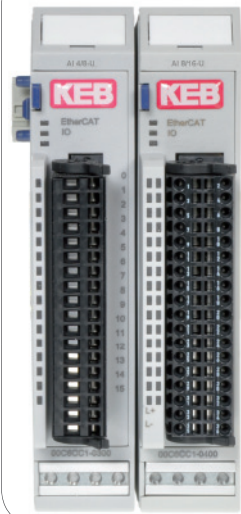

AI4/8-U

Analog inputs	8 single ended or 4 differential
Resolution	13 Bit (1.221 μ V unipolar/ 2.422 μ V bipolar)
Measuring range	0...10 V, \pm 10 V
Limiting frequency	1.12 kHz (if all channels are active)
E-Bus load	190 mA

AI8/16-U

Analog inputs	16 single ended or 8 differential
Resolution	13 Bit (1.221 μ V unipolar/ 2.422 μ V bipolar)
Measuring range	0...10 V, \pm 10 V
Limiting frequency	0.52 kHz (if all channels are active)
E-Bus load	220 mA

KEB REMOTE I/O EtherCAT Analog IN



AI4-I

Analog inputs	4
Resolution	12 Bit (5.2 μ A)
Measuring range	0...20 mA, 4...20 mA (limit 21.368 mA)
Sampling frequency	1.45 kHz (if all channels are active)
E-Bus load	140 mA

AI8-I

Analog inputs	8
Resolution	12 Bit (5.2 μ A)
Measuring range	0...20 mA, 4...20 mA (limit 21.368 mA)
Sampling frequency	0.76 kHz (if all channels are active)
E-Bus load	160 mA

KEB REMOTE I/O EtherCAT Analog OUT



AO4-U/I

Analog outputs	4
Resolution	12/16 Bit
Output signal	0...10 V, \pm 10 V, 0...20 mA, \pm 20 mA
Output frequency	3.125 kHz (constant)
E-Bus load	150 mA

KEB REMOTE I/O EtherCAT Analog IN



AI4-Pt/Ni100

Analog Inputs	4
Resolution	16 Bit
Measuring range Pt100	-75 °C...+670 °C
Measuring range Ni100	-60 °C...+250 °C
Measuring range resistance	70...330 Ω
Limiting frequency	7.75 Hz (4 channels)
E-Bus load	150 mA

AI8-Pt/Ni100

Analog Inputs	8
Resolution	16 Bit
Measuring range Pt100	-75 °C...+670 °C
Measuring range Ni100	-60 °C...+250 °C
Measuring range resistance	70...330 Ω
Limiting frequency	3.88 Hz (8 channels)
E-Bus load	170 mA

AI4-Pt/Ni1000

Analog Inputs	4
Resolution	16 Bit
Measuring range Pt1000	-75 °C...+570 °C
Measuring range Ni1000	-60 °C...+250 °C
Measuring range resistance	700...3000 Ω
Limiting frequency	7.75 Hz (4 channels)
E-Bus load	150 mA

AI8-Pt/Ni1000

Analog Inputs	8
Resolution	16 Bit
Measuring range Pt1000	-75 °C...+570 °C
Measuring range Ni1000	-60 °C...+250 °C
Measuring range resistance	700...3000 Ω
Limiting frequency	3.88 Hz (8 channels)
E-Bus load	170 mA

34

KEB REMOTE I/O EtherCAT Analog IN



AI4-thermo element

Analog Inputs	4
Resolution	16 Bit
Measuring range type K	-200 °C...+1372 °C (Resolution 0.1 °C)
Measuring range mV	-40...+65 mV (Resolution 2 μV)
Limiting frequency	7.63 Hz (4 channels)
E-Bus load	150 mA

AI8-Thermoelement

Analog Inputs	8
Resolution	16 Bit
Measuring range type K	-200 °C...+1372 °C (Resolution 0.1 °C)
Measuring range mV	-40...+65 mV (Resolution 2 μV)
Limiting frequency	3.82 Hz (8 channels)
E-Bus load	170 mA

KEB REMOTE I/O EtherCAT Counter 2 Fast Input (DI8) / Encoder



Encoder	2 A, B, Ref
Encoder type	5 V (RS422)
Count rate	max. 400kHz
Digital inputs	8
Input delay	1 ms
Signal level	Off: -3...5 V; On: 15...30 V (EN61131-3, Typ1)
Digital outputs	2
max. current	2 A for each output
Voltage supply	by EtherCAT coupler via E-Bus-plug
E-Bus load	300 mA

KEB REMOTE I/O EtherCAT Extender



Function	Extension of a C6 REMOTE I/O-Blocks. Changes the transmitting physics of LVDS (E-Bus) on 100Base-Tx
Controller	ASIC ET1100
Baud rate	100 Mbit/s
Cable	CAT5
Cable length	max. 100 m
Connection EtherCAT	2 x RJ45
Voltage supply	via E-Bus
E-Bus load	160 mA for OUT1 210 mA for OUT1 + OUT2

KEB REMOTE I/O EtherCAT Profibus-DP-Slave



Voltage supply	by EtherCAT coupler via E-Bus-plug
Potential separation	Modules electrically insulated from one another and from the bus
Storage temperature	-25 °C...+70 °C
Operating temperature	0 °C...+55 °C
Relative humidity	5...95 %, without condensation
Degree of protection	IP20
E-Bus load	210 mA

Headquarters

KEB - Karl E. Brinkmann GmbH

Försterweg 36 - 38 • D - 32683 Barntrup
Telefon +49 5263 401-0 • Telefax 401-116
Internet: www.keb.de • E-Mail: info@keb.de



KEB Antriebstechnik GmbH • Geared Motors
Wildbacher Straße 5 • D - 08289 Schneeberg
Telefon +49 3772 67-0 • Telefax 67-281
Internet: www.keb-drive.de • E-Mail: info@keb-drive.de

COMPANIES

AUSTRIA

KEB Antriebstechnik
Austria GmbH
Ritzstraße 8
A - 4614 Marchtrenk
Tel: +43 (0)7243 53586-0
Fax: +43 (0)7243 53586-21
E-mail: info@keb.at
Internet: www.keb.at

CHINA

KEB Power Transmission
Technology (Shanghai) Co. Ltd.
No. 435 QianPu Road
Songjiang East Industrial Zone
CN-201611 Shanghai, P.R. China
Tel: +86 (0)21 37746688
Fax: +86 (0)21 37746600
E-mail: info@keb.cn
Internet: www.keb.cn

FRANCE

Société Française KEB
Z.I. de la Croix St. Nicolas
14, rue Gustave Eiffel
F - 94510 LA QUEUE EN BRIE
Tel: +33 (0)149620101
Fax: +33 (0)145767495
E-mail: info@keb.fr
Internet: www.keb.fr

GREAT BRITAIN

KEB (UK) Ltd.
Morris Close
Park Farm Industrial Estate
GB - Wellingborough
NN8 6 XF
Tel: +44 (0)1933 402220
Fax: +44 (0)1933 400724
E-mail: info@keb-uk.co.uk
Internet: www.keb-uk.co.uk

ITALY

KEB Italia S.r.l. Unipersonale
Via Newton, 2
I - 20019 Settimo Milanese (Milano)
Tel: +39 02 3353531
Fax: +39 02 33500790
E-mail: info@keb.it
Internet: www.keb.it

JAPAN

KEB - Japan Ltd.
15 - 16, 2 - Chome
Takanawa Minato-ku
J - Tokyo 108 - 0074
Tel: +81 (0)33 445-8515
Fax: +81 (0)33 445-8215
E-mail: info@keb.jp
Internet: www.keb.jp

RUSSIA

KEB CIS ZAO
Lesnaya str, house 30
Dzerzhinsky (MO)
RUS - 140091 Moscow region
Tel: +7 (0)495 6320217
Fax: +7 (0)495 6320217
E-Mail: info@keb.ru
Internet: www.keb.ru

USA

KEB America, Inc
5100 Valley Industrial Blvd. South
USA - Shakopee, MN 55379
Tel: +1 952 2241400
Fax: +1 952 2241499
E-mail: info@kebameric.com
Internet: www.kebameric.com

Representative offices

- Belgium
- Brazil
- Korea
- Sweden
- Spain

Further partners for ...

Australia • Belgium • Bulgaria • Czech Republic • Denmark • Egypt • Greece • Hungary • India • Indonesia • Iran • Israel • Malaysia • Morocco • Netherlands • New Zealand • Pakistan • Poland • Portugal • Romania • Singapore • Slovakia • South Africa • Spain • Sweden • Switzerland • Taiwan • Thailand • Tunisia • Turkey • Uzbekistan

... under www.keb.de/en/contact/keb-worldwide.html



© KEB 00.00.000-52C6 /08-2013 • Subject to technical alterations!

