



STEPPING MOTORS

2-Phase Hybrid Type

1.8° Full Step Angle

SCHRITTMOTOREN

2-Phasen Hybrid-Schrittmotoren

1,8° Vollschrittwinkel



SECM296er Baureihe

2 Phasenschrittmotor
[1,8° High-Torque-Version]

| Model | | Unip Bipo | Holding Torque (Nm) | Current /Phase (Amps) | Resistance /Winding (Ohms) | Inductance /Winding (mH) | Number of Leads | Weight Rotor Inertia |
|----------------|----------------|--------------|---------------------------|-----------------------------|----------------------------------|--------------------------------|-----------------------|---------------------------------|
| Single Shaft | Double Shaft | | | | | | | |
| SECM296-E4.5AE | SECM296-E4.5BE | X | 2.45 | 4.5 | 0.4 | 1.6 | 8 | 2.1 Kg 1.6 Kgcm ² |
| SECM296-E4.5AE | SECM296-E4.5BE | X | 3.7 | 6.4 | 0.2 | 1.6 | | |

* Doppelwellenlänge = 34 +/-1 mm, Abflachung wie Vorderwelle

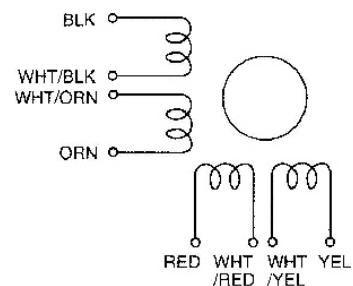
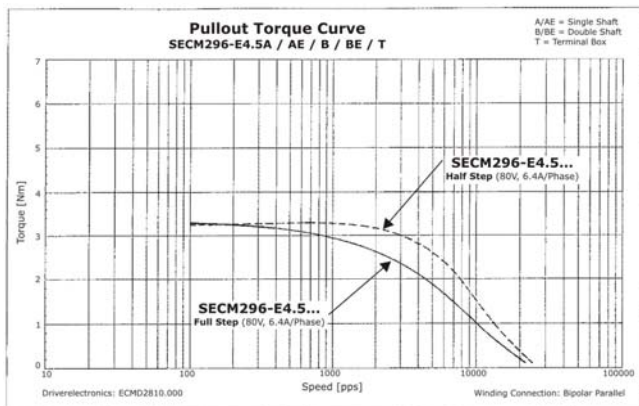
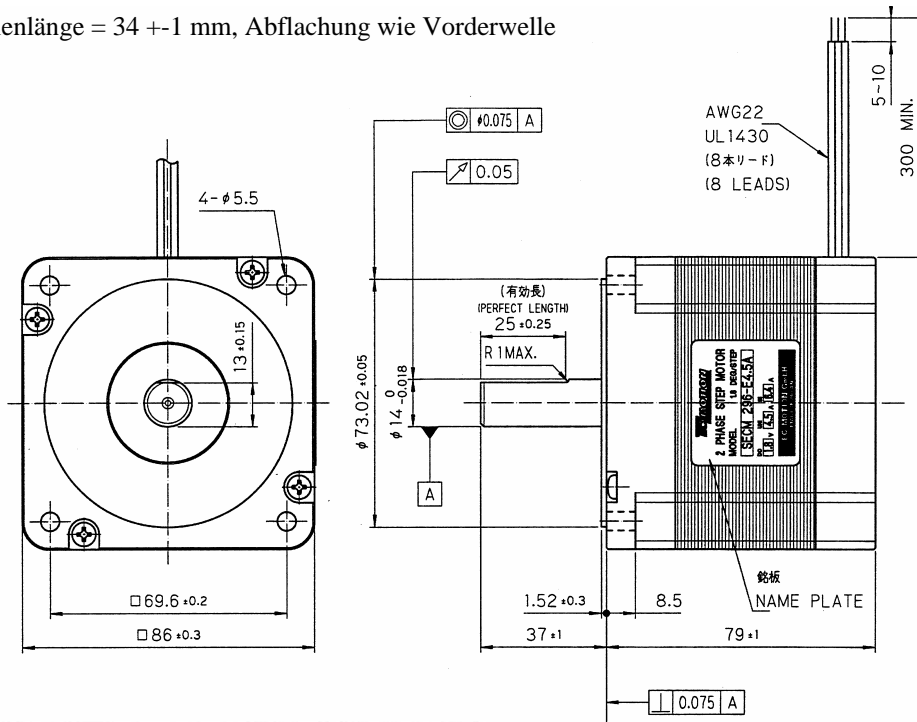

Optional sind für unsere Schrittmotoren Encoder und / oder Planetengetriebe erhältlich.



EC Motion GmbH - Auf den Steinen 20 - 41812 Erkelenz
Tel.: +49 (0)2164-7014-0 - Fax. : +49 (0)2164-701419
Internet: www.ec-motion.de - e-mail: info@ec-motion.de





SECM296er Baureihe

2 Phasenschrittmotor m. Anschlußkasten
[1,8° High-Torque-Version]

| Model | Unip Bipo | Holding Torque (Nm) | Current /Phase (Amps) | Resistance /Winding (Ohms) | Inductance /Winding (mH) | Number of Leads | Weight Rotor Inertia |
|------------------|--------------|---------------------------|-----------------------------|----------------------------------|--------------------------------|-----------------------|---------------------------------|
| Single Shaft | | | | | | | |
| SECM296-E4.5AE-T | X | 2.45 | 4.5 | 0.4 | 1.6 | 8 | 2.5 Kg 1.6 Kgcm ² |
| | X | 3.7 | 6.4 | 0.2 | 1.6 | | |

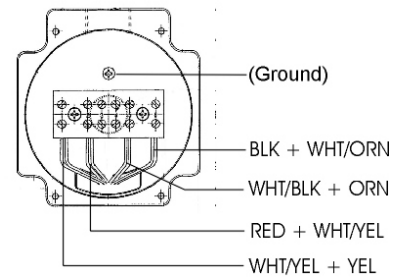
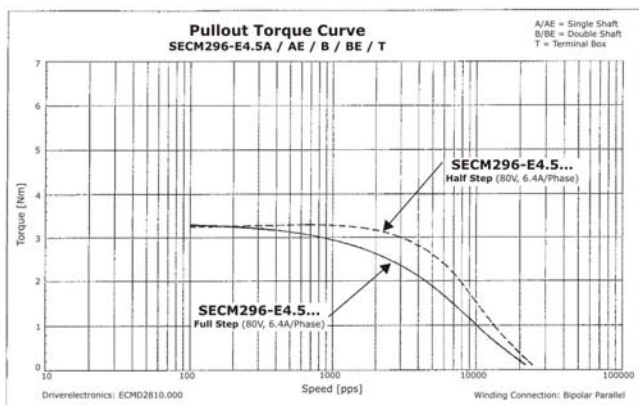
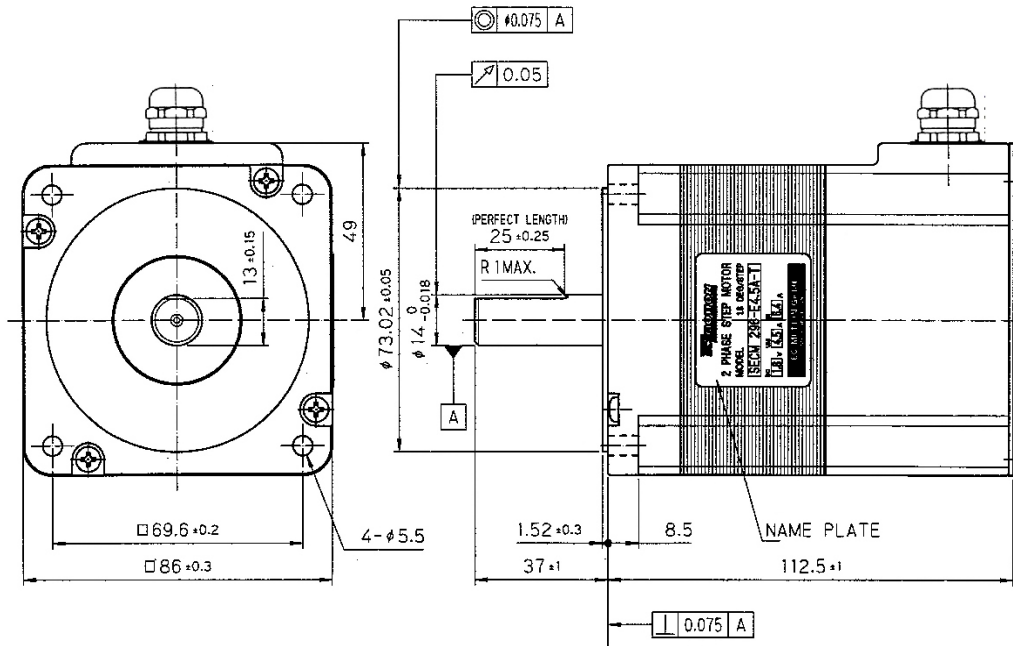

Optional sind für unsere Schrittmotoren Encoder und / oder Planetengetriebe erhältlich.



SECM299er Baureihe

2 Phasenschrittmotor
[1,8° High-Torque-Version]

| Model | | Unipolar | Bipolar | Holding Torque (Nm) | Current /Phase (Amps) | Resistance /Winding (Ohms) | Inductance /Winding (mH) | Number of Leads | Weight |
|----------------|----------------|----------|---------|---------------------|-----------------------|----------------------------|--------------------------|-----------------|---------------------------------|
| Single Shaft | Double Shaft | | | | | | | | Rotor Inertia |
| SECM299-E4.5AE | SECM299-E4.5BE | X | | 5.4 | 4.5 | 0.6 | 3.1 | 8 | 3.5 Kg 3.2 Kgcm ² |
| SECM299-E4.5AE | SECM299-E4.5BE | | X | 7.3 | 6.4 | 0.3 | 3.1 | | |
| SECM299-E6.4AE | SECM299-E6.4BE | X | | 5.0 | 6.4 | 0.32 | 1.1 | | |
| SECM299-E6.4AE | SECM299-E6.4BE | | X | 6.9 | 9.0 | 0.16 | 1.1 | | |

* Doppelwellenlänge = 34 +-1 mm, Abflachung wie Vorderwelle

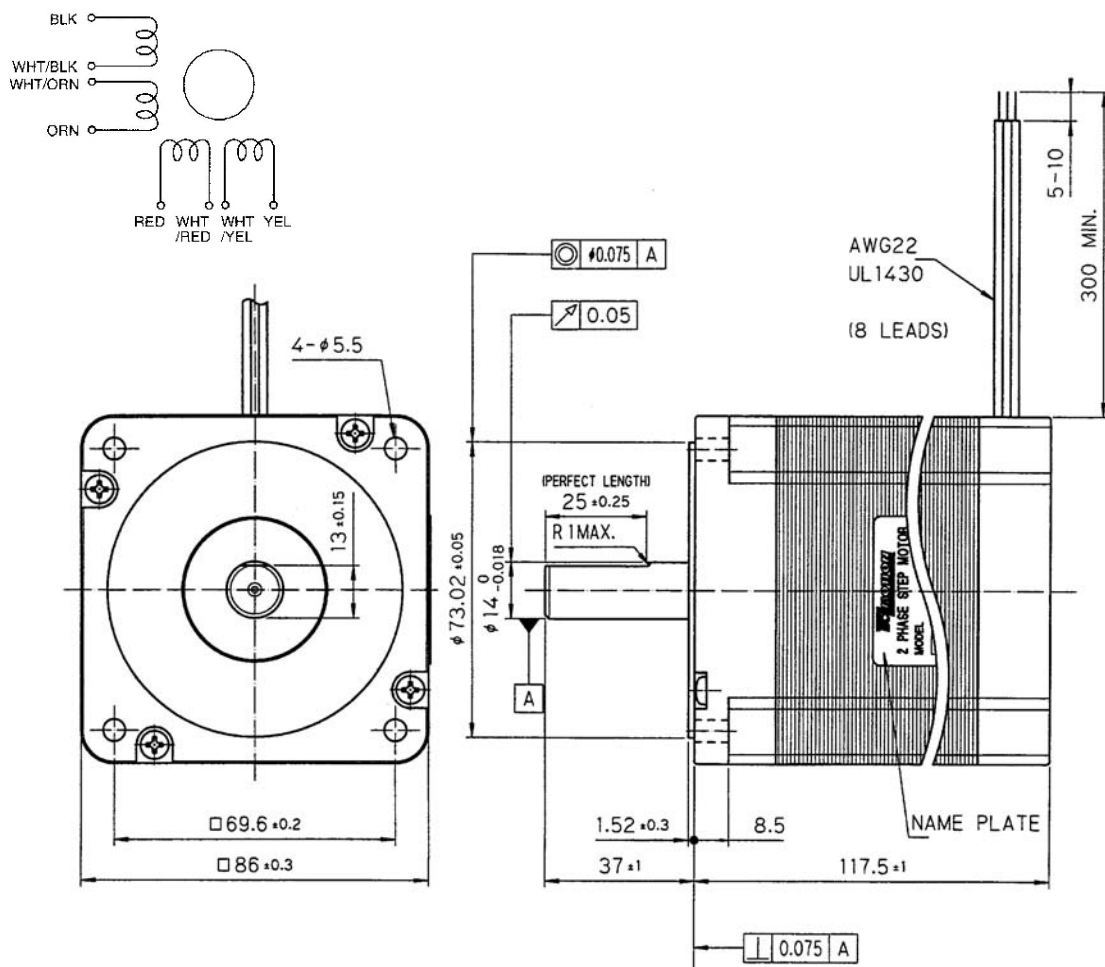

Optional sind für unsere Schrittmotoren Encoder und / oder Planetengetriebe erhältlich.



SECM299er Baureihe

2 Phasenschrittmotor m. Anschlußkasten
[1,8° High-Torque-Version]

| Model | Unipolar Bipolar | Holding Torque (Nm) | Current /Phase (Amps) | Resistance /Winding (Ohms) | Inductance /Winding (mH) | Number of Leads | Weight |
|------------------|---------------------|---------------------------|-----------------------------|----------------------------------|--------------------------------|-----------------------|---------------------------------|
| | | | | | | | Rotor Inertia |
| SECM299-E4.5AE-T | X | 5.4 | 4.5 | 0.6 | 3.1 | 8 | 3.5 Kg 3.2 Kgcm ² |
| | X | 7.3 | 6.4 | 0.3 | 3.1 | | |
| SECM299-E6.4AE-T | X | 5.0 | 6.4 | 0.32 | 1.1 | | |
| | X | 6.9 | 9.0 | 0.16 | 1.1 | | |

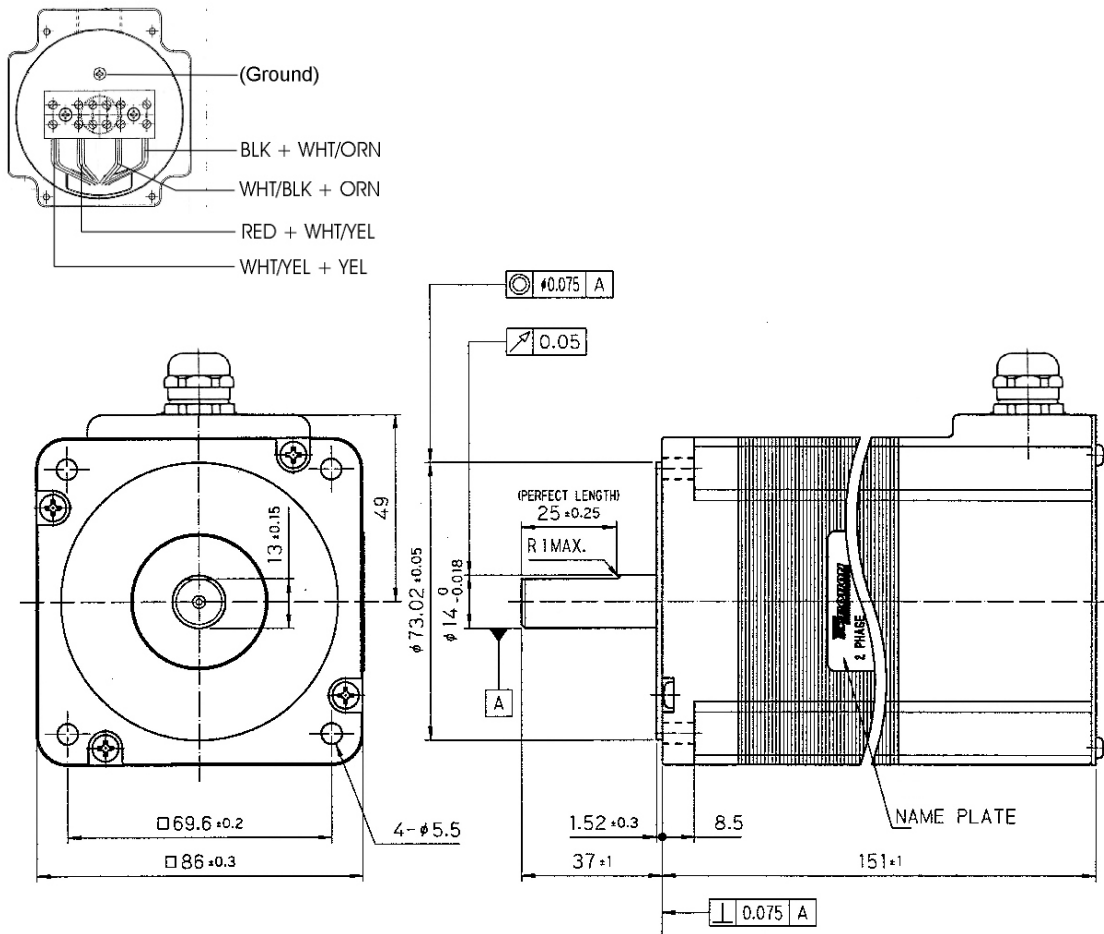

Optional sind für unsere Schrittmotoren Encoder und / oder Planetengetriebe erhältlich.

A/AE = Single Shaft
 B/BE = Double Shaft
 T = Terminal Box
 Curve = bipolar par.

Pullout Torque Curve SECM299-E4.5A / AE / B / BE / T - SECM299-E6.4A / AE / B / BE / T

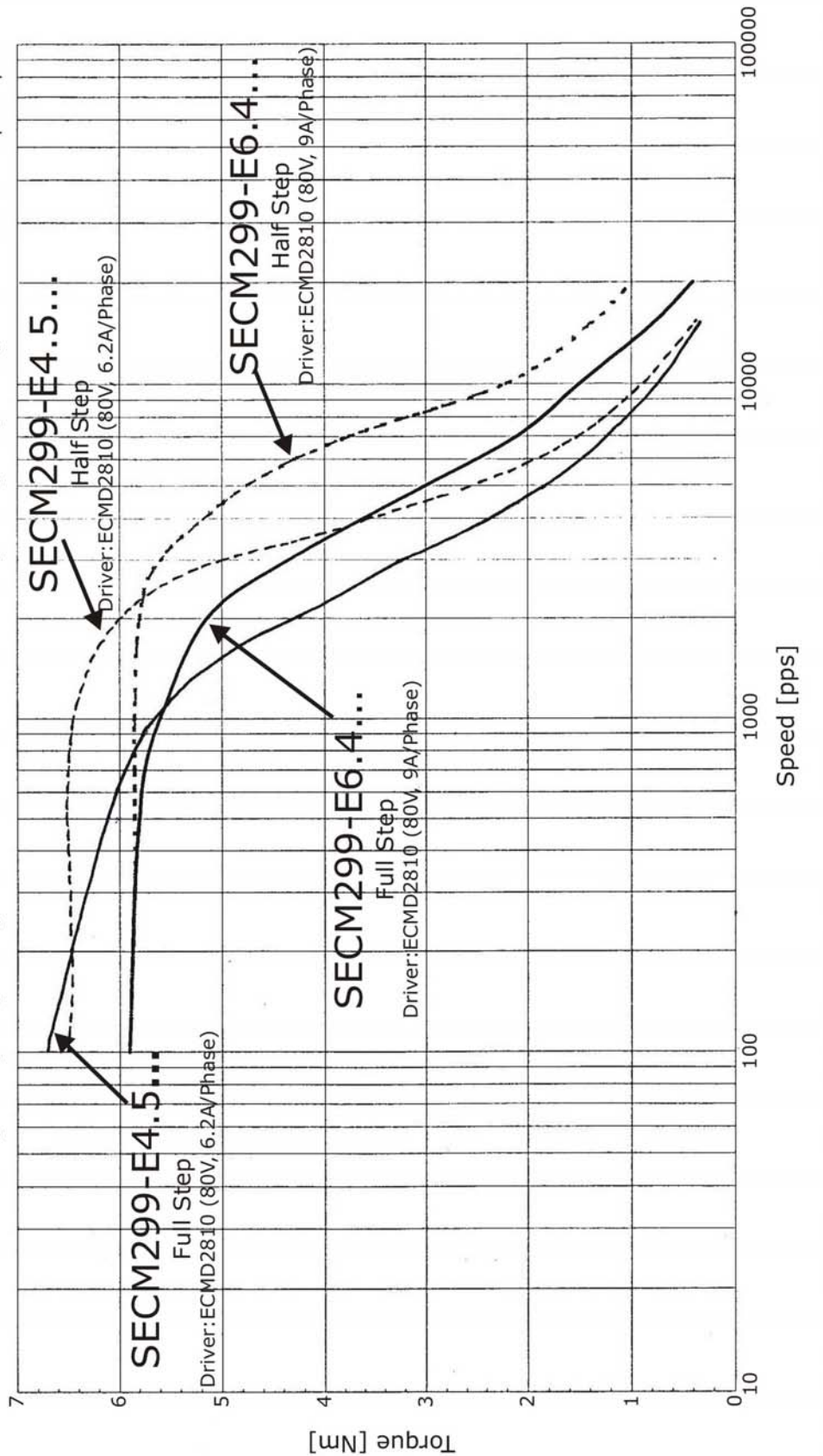



SECM2913er Baureihe

2 Phasenschrittmotor
[1,8° High-Torque-Version]

| Model | | Unipolar | Bipolar | Holding Torque (Nm) | Current /Phase (Amps) | Resistance /Winding (Ohms) | Inductance /Winding (mH) | Number of Leads | Weight |
|-----------------|-----------------|----------|---------|---------------------|-----------------------|----------------------------|--------------------------|-----------------|---------------------------------|
| Single Shaft | Double Shaft | | | | | | | | Rotor Inertia |
| SECM2913-E4.0AE | SECM2913-E4.0BE | X | | 7.4 | 4.0 | 0.85 | 4.6 | 8 | 5.0 Kg 4.8 Kgcm ² |
| SECM2913-E4.0AE | SECM2913-E4.0BE | | X | 10.2 | 5.7 | 0.43 | 4.6 | | |
| SECM2913-E6.4AE | SECM2913-E6.4BE | X | | 7.4 | 6.4 | 0.38 | 1.7 | | |
| SECM2913-E6.4AE | SECM2913-E6.4BE | | X | 10.2 | 9.0 | 0.19 | 1.7 | | |

* Doppelwellenlänge = 34 +-1 mm, Abflachung wie Vorderwelle

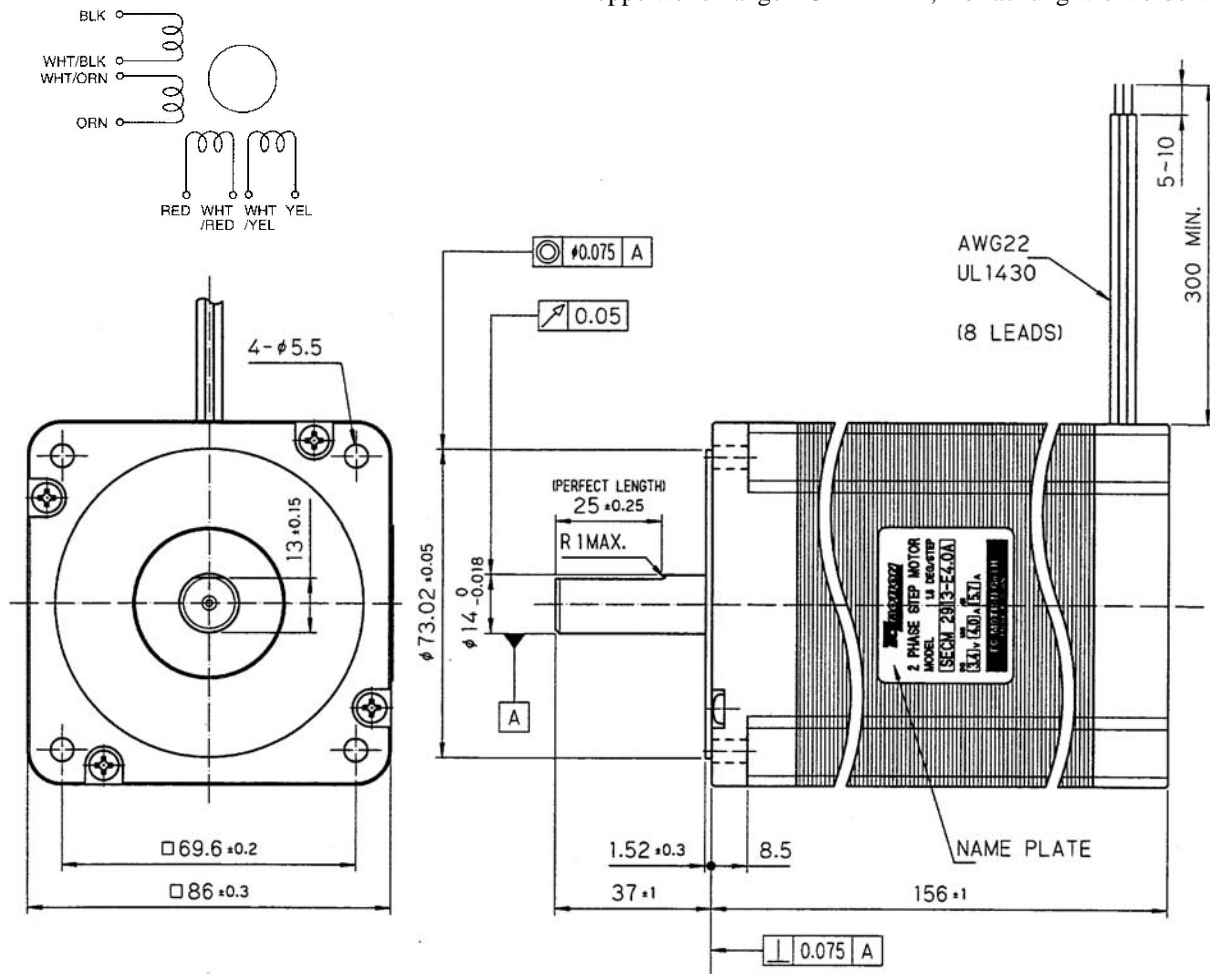

Optional sind für unsere Schrittmotoren Encoder und / oder Planetengetriebe erhältlich.

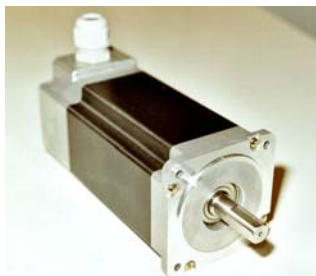

SECM2913er Baureihe

2 Phasenschrittmotor m. Anschlußkasten
[1,8° High-Torque-Version]

| Model | Unipolar Bipolar | Holding Torque (Nm) | Current /Phase (Amps) | Resistance /Winding (Ohms) | Inductance /Winding (mH) | Number of Leads | Weight |
|-------------------|---------------------|---------------------------|-----------------------------|----------------------------------|--------------------------------|-----------------------|---------------------------------|
| | | | | | | | Rotor Inertia |
| SECM2913-E4.0AE-T | X | 7.4 | 4.0 | 0.85 | 4.6 | 8 | 5.0 Kg 4.8 Kgcm ² |
| | X | 10.2 | 5.7 | 0.43 | 4.6 | | |
| SECM2913-E6.4AE-T | X | 7.4 | 6.4 | 0.38 | 1.7 | | |
| | X | 10.2 | 9.0 | 0.19 | 1.7 | | |

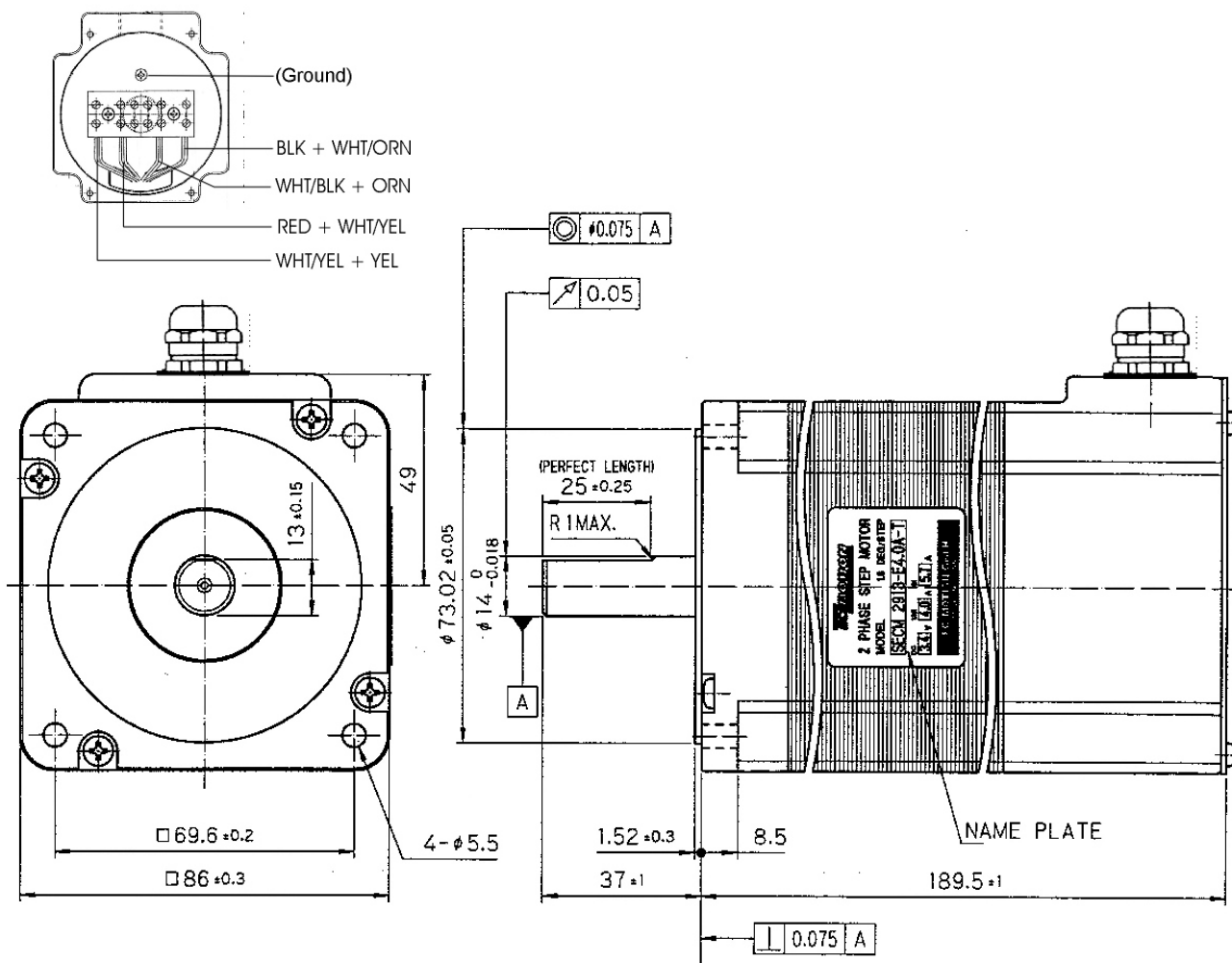

Optional sind für unsere Schrittmotoren Encoder und / oder Planetengetriebe erhältlich.

